



# EARTH MOVING SERIES

LD, GP, and MD Box Scrapers

Operation, Maintenance, and Parts Manual



DO NOT OPERATE THIS EQUIPMENT UNTIL THIS MANUAL HAS BEEN READ AND UNDERSTOOD.



Part Number: 1350003 R0

Revised: 2025-Apr-08

Original Instructions

# Serial Number and Product-Specific Information

- The serial number location for this scraper can be found in the location shown below.
- Always give the dealer the serial number on the scraper when ordering parts, requesting service, or requesting other information.
- Please record the information in the table below for easy reference.

Model Number		Serial Number	
Date of Purchase			
Dealer	Dealer Phone Number		
City	State	Zip	

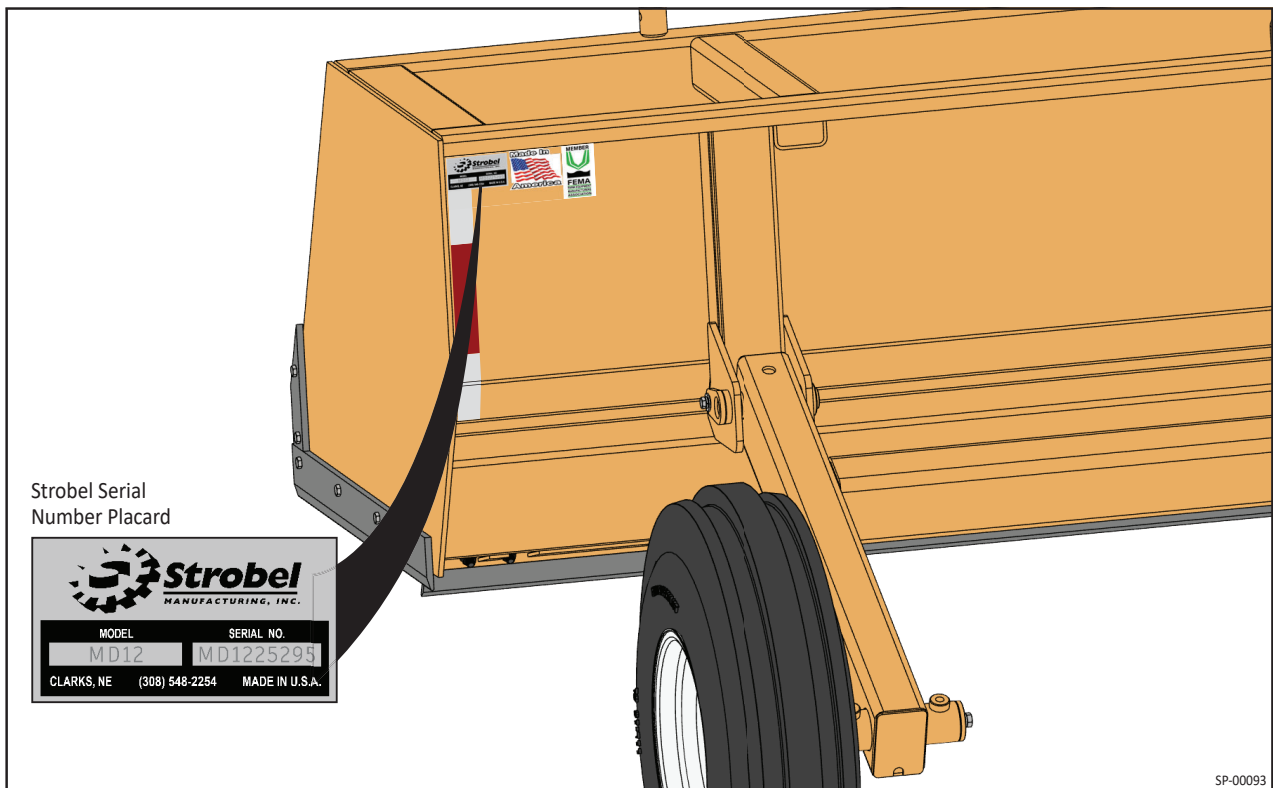

# Contents



Serial Number and Product-Specific Information .....	2
<b>Safety</b> .....	5
Safety Alert Symbol and Signal Words .....	6
General Safety Information .....	6
Safety Decals .....	7
Safety Decal Details and Locations .....	7
Before Operating .....	11
Transport Safety .....	12
SMV and SIS Signs .....	13
Working On or Near This Implement .....	14
Hydraulic Power and Pressurized Oil Safety .....	15
Wear Personal Protective Equipment .....	16
Prepare for Emergencies .....	17
<b>Operation</b> .....	18
Operating Safety .....	19
Features .....	20
LD Scraper Main Features Identification .....	20
GP Scraper Main Features Identification .....	22
MD Scraper Main Features Identification .....	24
Hitch Assemblies .....	26
Scraper Specifications .....	27
Preparation .....	28
Preparing the Tractor .....	28
Purging Air From the Hydraulic System .....	28
Preparing the Jack Assembly .....	29
Turning the Hydraulic Cylinder Lock Valve ON or OFF .....	30
Hitching/Unhitching the Implement .....	31
Moving the Tractor Into Position .....	31
Hitching the Implement to the Tractor .....	31
Checking the Implement Before Operating or Transporting .....	32
Verify the Equipment is Ready for Operation or Transport .....	32
Visually Inspecting Before Operation or Transport .....	32
Preparing the Hydraulics Before Operating .....	33
Staying Safe on Inclines .....	33
Transporting the Scraper .....	34
Before Transporting .....	34
During Transport .....	34
Operating the Scraper .....	35
General Operation .....	35

<b>Maintenance</b> .....	37
Maintenance Safety .....	38
Securing and Supporting the Scraper for Maintenance .....	38
Scraper Support Points .....	39
Bolt Torque .....	40
Storing the Implement.....	41
Maintenance Schedule .....	41
Lubrication Guide and Schedule .....	42
Back Side Lubrication Points .....	42
MD Clevis Hitch Lubrication Points.....	43
Checking for Proper Tire Pressure.....	43
Replacing a Wheel.....	44
Removing a Wheel .....	44
Installing a Wheel.....	44
<b>Replacements and Parts</b> .....	45
Replacement and Parts Safety.....	46
Replacing the Blades.....	47
Removing Blades.....	47
Installing Blades .....	47
LD 6, 8, and 10 Models Replacement Parts.....	50
Spindle and Hub Assembly .....	50
Blade/Blade Bolts, Hydraulic Cylinder, Jack Assembly, and Wheel/Tire Assembly .....	51
Hydraulic System Replacement Parts .....	52
GP 8, 10, and 12 Models Replacement Parts .....	53
Spindle and Hub Assembly .....	53
Blade/Blade Bolts, Hydraulic Cylinder, Jack Assembly, and Wheel/Tire Assembly .....	54
Axle Assembly.....	55
Hydraulic System Replacement Parts .....	56
MD 8, 10, 12, and 14 Models Replacement Parts.....	57
Single Wheel Spindle and Hub Assembly.....	57
Dual Wheel Spindle and Hub Assembly.....	58
Blade/Blade Bolts, Hydraulic Cylinders, Jack Assembly, and Wheel/Tire Assembly .....	59
Axle Assembly.....	60
Hydraulic System Replacement Parts .....	61
Swivel Hitch Assembly.....	62
<b>Troubleshooting</b> .....	63

# Safety



Safety Alert Symbol and Signal Words.....	6
General Safety Information .....	6
Safety Decals .....	7
Safety Decal Details and Locations .....	7
Before Operating.....	11
Transport Safety .....	12
SMV and SIS Signs .....	13
Working On or Near This Implement.....	14
Hydraulic Power and Pressurized Oil Safety .....	15
Wear Personal Protective Equipment.....	16
Prepare for Emergencies .....	17

## Safety Alert Symbol and Signal Words



- This safety symbol indicates an important safety message in this manual.
- When you see this symbol, be alert to the possibility of injury or death.

**Signal Words:** Be aware of the signal words **DANGER**, **WARNING**, **CAUTION**, and **NOTICE**. These signal words indicate a level of safety risk.



**DANGER** Indicates extremely imminent hazards where death or serious injury will result if these hazards are not avoided.



**WARNING** Indicates hazards at hand where death or serious injury likely could occur if these hazards are not avoided.



**CAUTION** Indicates hazards at hand where personal injury likely may occur if these hazards are not avoided.



**NOTICE** Used to convey important information that is not related to personal safety, such as maintenance, cleaning guidelines, avoiding implement damage, and the like.

GS-0001

## General Safety Information



All safety information in this manual is essential and is intended to assist in identifying and preventing incidents that could cause injury, death, or property damage. *Read, understand, and follow this manual and all safety instructions before operating, maintaining, or working near this equipment.*

- **Safety is your responsibility.** As the owner, operator, or supervisor you need to know and be alert to the specific requirements, precautions, and hazards that exist and to make these known to all personnel working with the equipment or in the equipment area, so they too may take any necessary safety precautions that may be required.
- **Prevent accidents by anticipating the result before the accident is caused.** As an owner, operator, or supervisor you are responsible.
- **Allow only experienced personnel to operate this equipment.** Operators need to be trained and familiar with this type of equipment.
- **Never use the equipment for purposes or applications it is not designed for.**
- **Never use any equipment that is damaged or has become unsafe.**

GS-0000

## Safety Decals





- Make sure all safety decals/signs are present in each designated location, and install new decal(s) if any are missing or unreadable.
- Make sure replacement parts display the same safety decals.

SA-0001

### Safety Decal Details and Locations

- Following are Safety Decal Identification Images of implement decals with locations drawings showing where these decals attach to each implement model, along with the decal part number.
- Safety decals draw attention to safety concerns, precautions, and possible hazards.

SA-0003

<p>(A) Caution Pinch Point, 04039100</p> 	<p>(C) Warning High Pressure Fluid Hazard, 04039113</p> 
<p>(E) Grease Point, 04078007</p> 	<p>(G) Reflector Decal, 18190101</p> 
<p>(H) Reflector Strip</p> 	

### LD Safety Decals Locations

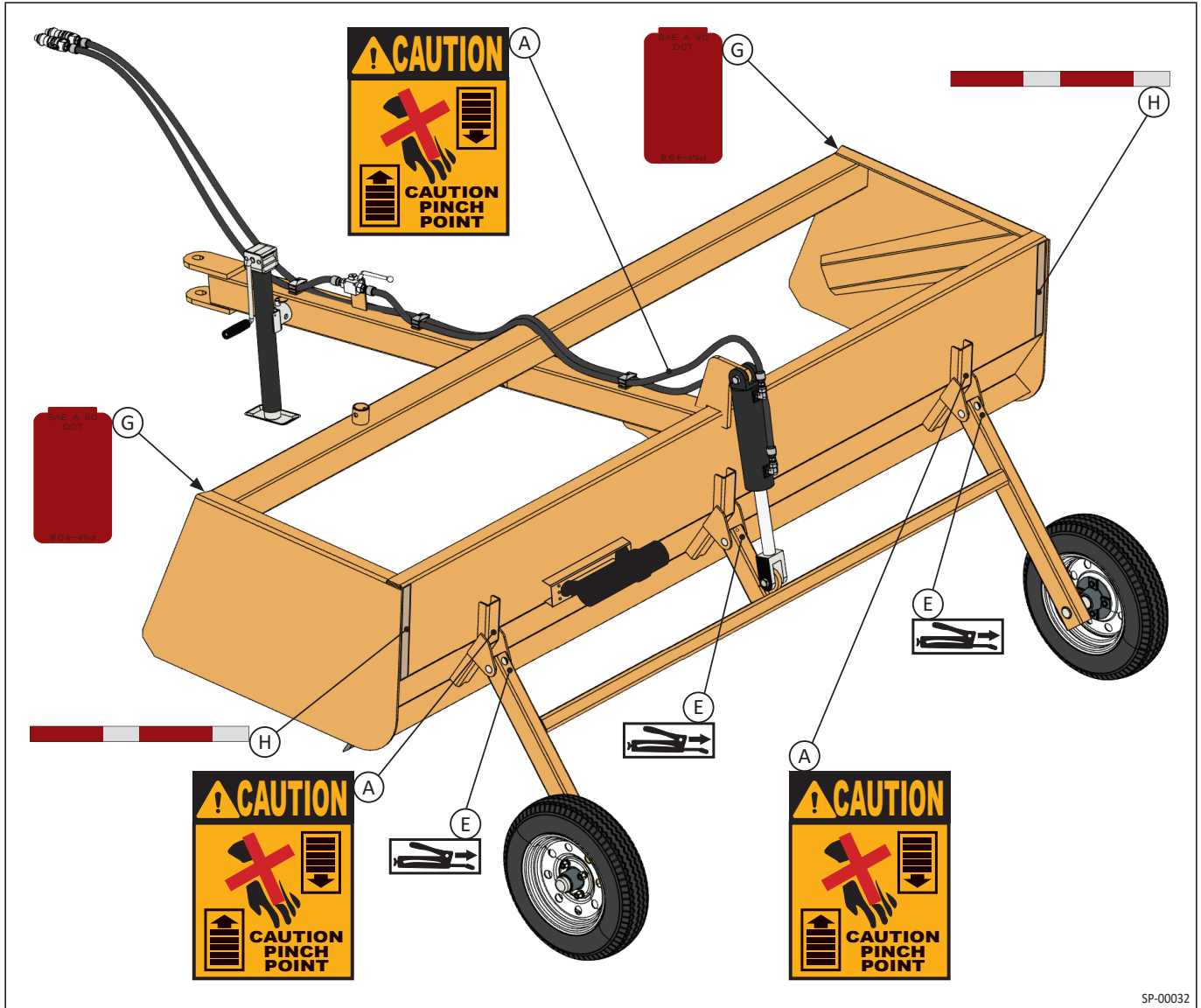

SP-00032

### GP Safety Decals Locations

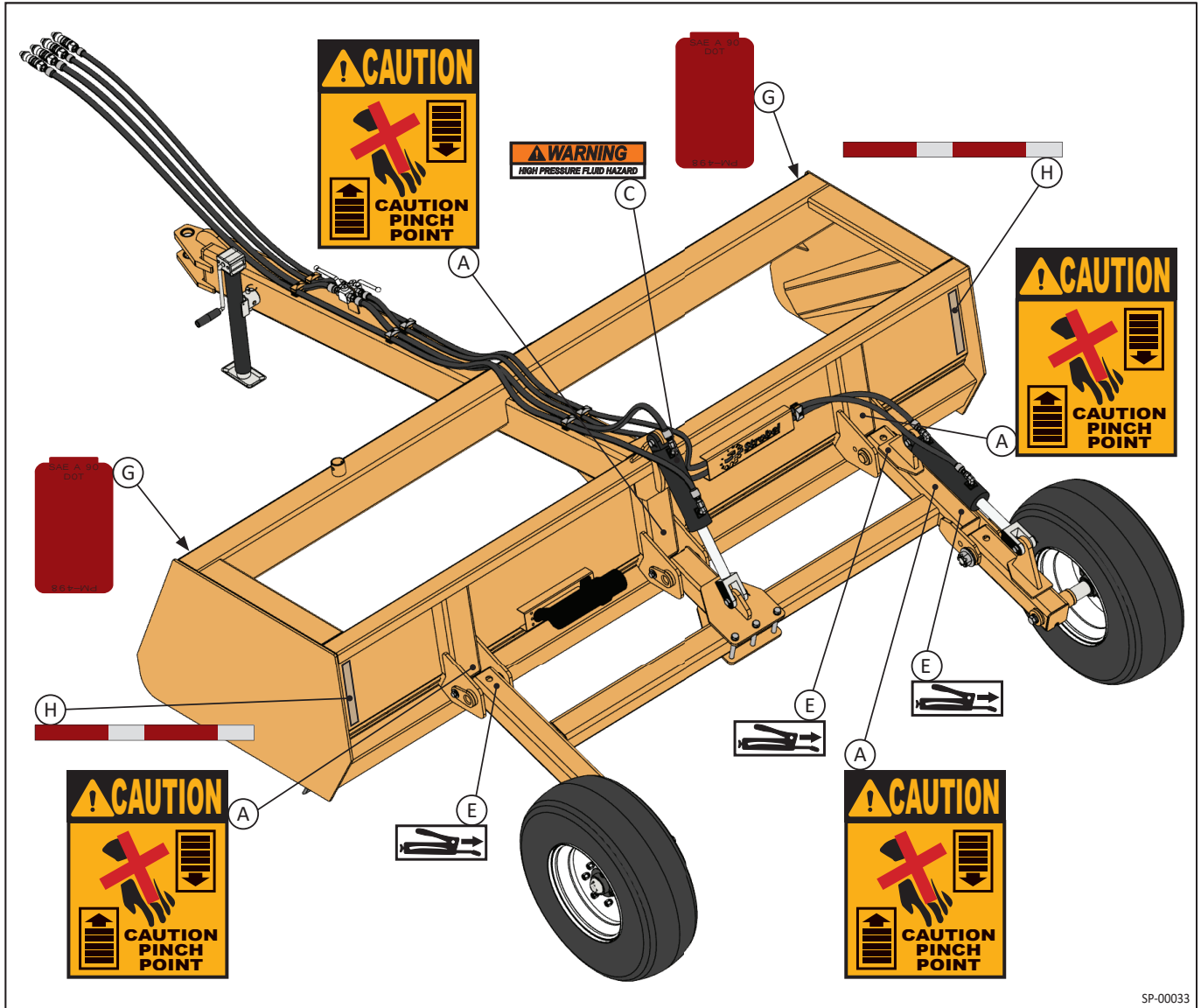

SP-00033

### MD Safety Decals Locations

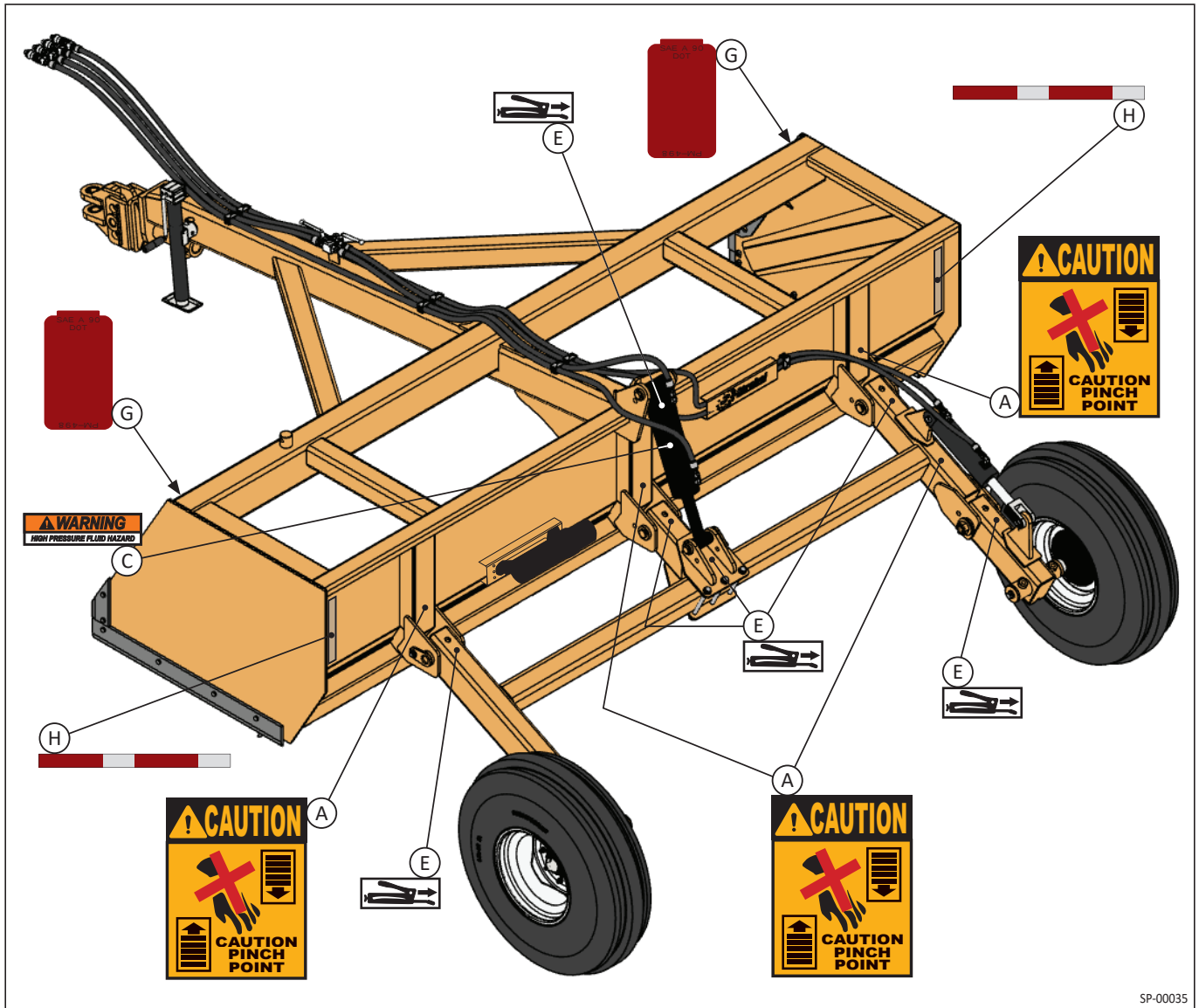

SP-00035

## Before Operating

### WARNING

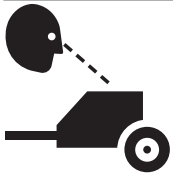

- Walk around the equipment and inspect it.



- Never allow anyone who is untrained or underage to drive the towing tractor/vehicle or to operate the implement. Refer to the applicable laws and safety rules within the local jurisdiction.



- Keep children, untrained persons, any others, and animals away from the implement when it is parked, operating, or moving. Never allow anyone to ride on or be on the implement.



- Always make sure all persons, animals, buildings, and objects are clear of the implement path and work area. Prevent striking, crushing, or running over persons or obstacles.

- Make sure all safety devices are properly installed.
- Check tire condition and make sure the tires have proper pressure.
- Make sure tractor drawbar, hitch pins, and safety locks are all in place and ready for towing.
- Make sure the implement hydraulic hoses are properly connected to the tractor hydraulic couplers and that hoses are routed properly to prevent kinking and damage during towing.
- Refer to and follow the tractor manual.

BB-0000

## Transport Safety

**⚠ WARNING**



- Use safe driving techniques for snow, ice, and the current driving conditions. Avoid driving with this equipment in the dark. Refer to the tractor manual.

- Use a tow vehicle of adequate size and capacity for towing the equipment.
- Adhere to all road safety laws and rules that apply within the local jurisdiction, including those pertaining to transport.
- Before transporting the equipment, close the hydraulic cylinder/blade locking valve.
- Operators, ensure lights and all government required safety devices are present and properly located on the equipment, day and night. This includes lights, flags, safety signs, emblems, reflectors, etc. This is your responsibility. Ensure all transport lights and transport safety devices are operational and clearly visible from the front, back, and sides of the equipment.
- Choose only safe roads and driving surfaces without holes or dips; reduce speeds if the road or ground is rough/uneven.
- Check clearances carefully and use caution when moving or operating the equipment around bridges, buildings, fences, ditches, etc.
- Notice and keep all equipment away from overhead powerlines and electrical power devices.
- Check clearances, use caution when operating around overhead power, obstructions, ditches, etc.

TS-0001

## SMV and SIS Signs

---



- When transporting this equipment, make sure it has a slow moving vehicle sign (SMV) installed in a location on the rear end of the vehicle visible to other vehicles from 500' away.
  - Install this emblem at a height of approximately 2'–6' from the ground.
- 



- When required in your jurisdiction, install a Speed Identification Symbol (SIS) sign in a visible location on the back of the equipment.
-

## Working On or Near This Implement

**⚠ WARNING**



- Never work on or under this implement or any part of it unless it's securely positioned, blocked, and supported. Make sure when it's supported, it's blocked and supported correctly so there is no possible way this implement or any part of this implement could ever move, crush, fall on, or cut a person or any of their body parts. Always use correct jacks that will not move or fail, and which are properly rated to support the weight.

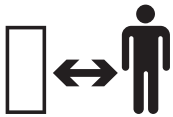

- Never allow anyone to be where they could be struck or run over by the equipment.



- During hitching, unhitching, and always, check that you and all others are in a safe location that prevents anyone from getting crushed. Make sure no one can get crushed between the equipment and a tractor, or the equipment and a structure.
- When working on the equipment including when lubricating the equipment, make sure both the tractor and implement are: stopped, cannot move, and resting on solid, level ground.



- Always keep hands, feet, and body clear of implement, cylinders, arms, hinges, hitch, pins, etc., and any other pinch points.
- Completely prevent becoming entangled in the equipment. Don't wear loose-fitting clothing, accessories, dangling items, baggy clothes, draw strings, etc. Secure or tie back long hair.



- Tire blow-out, rim failure, or explosive tire separation may cause injury or death. Only allow trained persons to service wheels and tires.



- Hydraulic fluid, lubricants, and grease are: poisonous, known to cause cancer, and known to cause reproductive harm. Ingesting these petroleum products can kill.



- Always shut off the tractor or towing vehicle engine and relieve all hydraulic pressure before performing maintenance on this equipment.

**⚠ WARNING**



- Only allow trained personnel to maintain or service the tire and wheel assembly.

- Use only safe work practices, methods, and procedures.
- Never allow maintenance or work to be performed on a scraper when it is hydraulically raised. Make sure the scraper is fully lowered.
- Make sure the implement is free of unnecessary sharp edges, and be careful to avoid cuts from sharp edges.
- Always use correct tools and equipment.

## Hydraulic Power and Pressurized Oil Safety

**⚠ WARNING**



- Escaping pressurized fluid can penetrate body tissue, cause death, or cause serious injury. Use cardboard or wood to check for hydraulic system leaks. Get immediate medical help if hydraulic fluids penetrate body tissue or injure.



- Always relieve all hydraulic system pressure before disconnecting from the tractor hydraulic system, making any adjustments, or performing maintenance on the hydraulic system.

- Always purge the air from the hydraulic system before operating. See “Purging Air from the Hydraulic System” in the Preparation section of this manual.
- Never raise the tractor hydraulic system pressure above 3000 psi. Implement hoses could burst.
- Position hoses and fittings carefully and to prevent failure due to kinking, rubbing, and weather exposure over time. Prevent hoses from being struck.
- Check hydraulic hoses and fittings periodically to prevent these from failing. Make sure all fittings, clamps, and hoses are installed properly and in good condition.
- Always repair any oil leaks. Repair any hoses that are kinked, crushed, weather cracked, or worn.
- If an accident occurs, seek medical attention immediately.

HP-0001

## Wear Personal Protective Equipment

**⚠ CAUTION**



- Always wear proper personal protective clothing and equipment appropriate for each task.
- Wear eye protection near flying particles, when near a hydraulic system/pressurized fluids, and when around potential eye hazards.



- Wear steel toed shoes during operation or when working on this equipment.



- Wear hearing protection when noise level is loud.
- Avoid wearing anything that could impair hearing such as earbuds or headphones.



- Wear protective work gloves.

## Prepare for Emergencies

**⚠ CAUTION**



- Keep a first aid kit on the towing vehicle. Ensure items are clean and properly stocked.



- Keep a fire extinguisher on the towing vehicle. Ensure it is properly charged.



- Keep an emergency call list for emergency medical, fire, rescue, and others near and on your phone.

# Operation



Operating Safety.....	19
Features .....	20
LD Scraper Main Features Identification.....	20
GP Scraper Main Features Identification .....	22
MD Scraper Main Features Identification .....	24
Hitch Assemblies .....	26
Scraper Specifications .....	27
Preparation.....	28
Preparing the Tractor.....	28
Purging Air From the Hydraulic System .....	28
Preparing the Jack Assembly.....	29
Turning the Hydraulic Cylinder Lock Valve ON or OFF .....	30
Hitching/Unhitching the Implement.....	31
Moving the Tractor Into Position.....	31
Hitching the Implement to the Tractor .....	31
Checking the Implement Before Operating or Transporting .....	32
Verify the Equipment is Ready for Operation or Transport.....	32
Visually Inspecting Before Operation or Transport.....	32
Preparing the Hydraulics Before Operating .....	33
Staying Safe on Inclines .....	33
Transporting the Scraper .....	34
Before Transporting.....	34
During Transport .....	34
Operating the Scraper.....	35
General Operation.....	35

## Operating Safety

### WARNING

---

*Read, understand, and follow all safety instructions in this manual, on the safety decals, and in the tractor manual before operating this equipment. Always follow all safety instructions.*

- Anticipate and identify hazards. Determine the potential safety risk of each hazard.
- Read and follow the “Before Operating Safety” section in this manual before starting operation. See the safety section in this manual.
- Make sure the brakes are in proper working order before operating or working on inclines.
- During hitching, unhitching, and always, check that you and all others are in a safe location that prevents anyone from getting crushed. Make sure no one can get crushed between the equipment and a tractor, or the equipment and a structure.
- Always make sure all persons, animals, buildings, and objects are clear of the implement path and work area. Prevent striking, crushing, or running over persons or obstacles.
- Only operate this machine while you are sitting in the tractor or towing vehicle driver seat. Always shut off the tractor, put it in park, and remove the key before leaving the driver seat.
- Always travel at a safe speed that allows you to maintain control of the implement and always maintain control of the implement.
- Use safe driving techniques for snow, ice, and the current driving conditions. Avoid driving with this equipment in the dark. Refer to the tractor manual.

---

OP-0000

# Features

## LD Scraper Main Features Identification

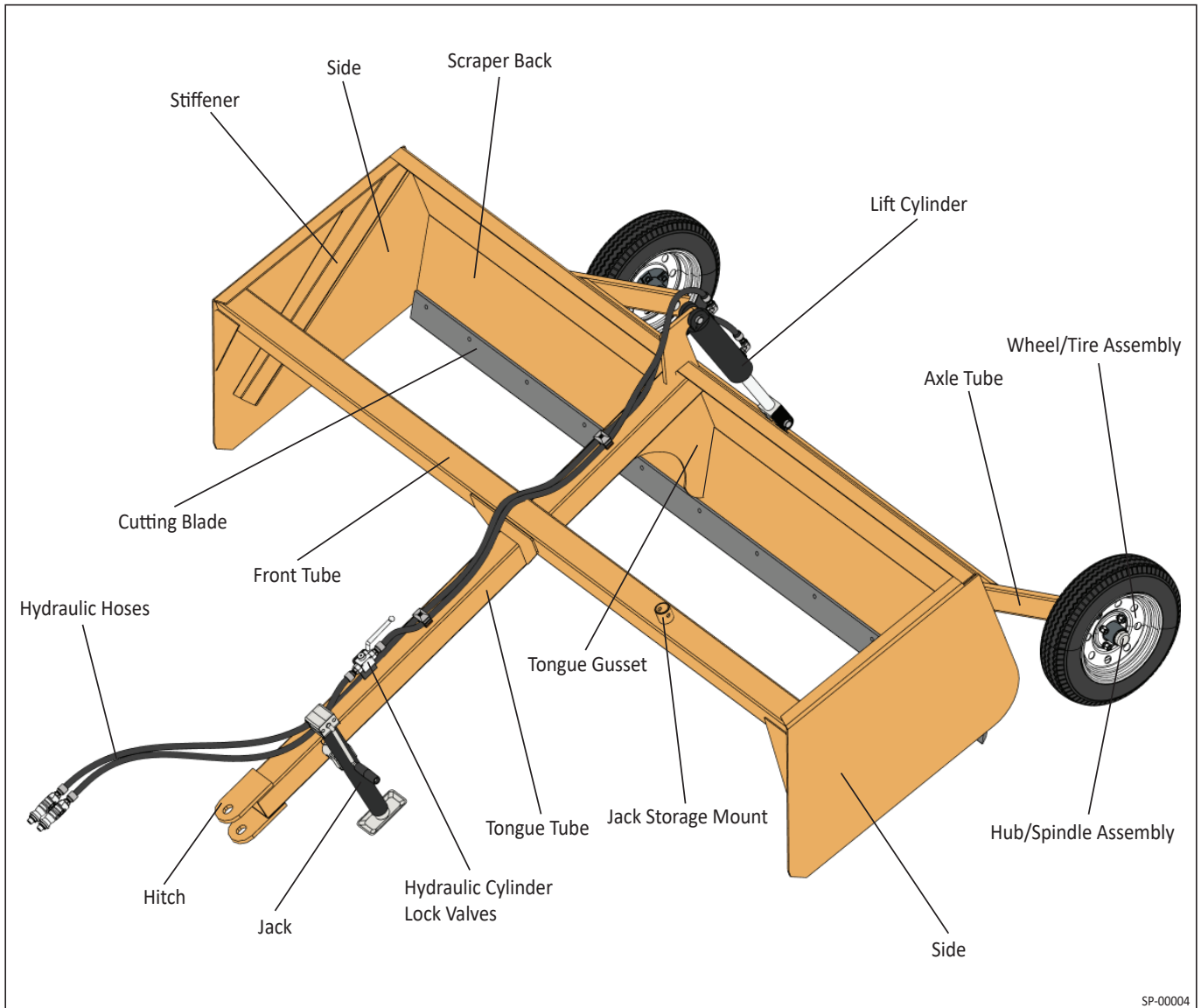

SP-00004

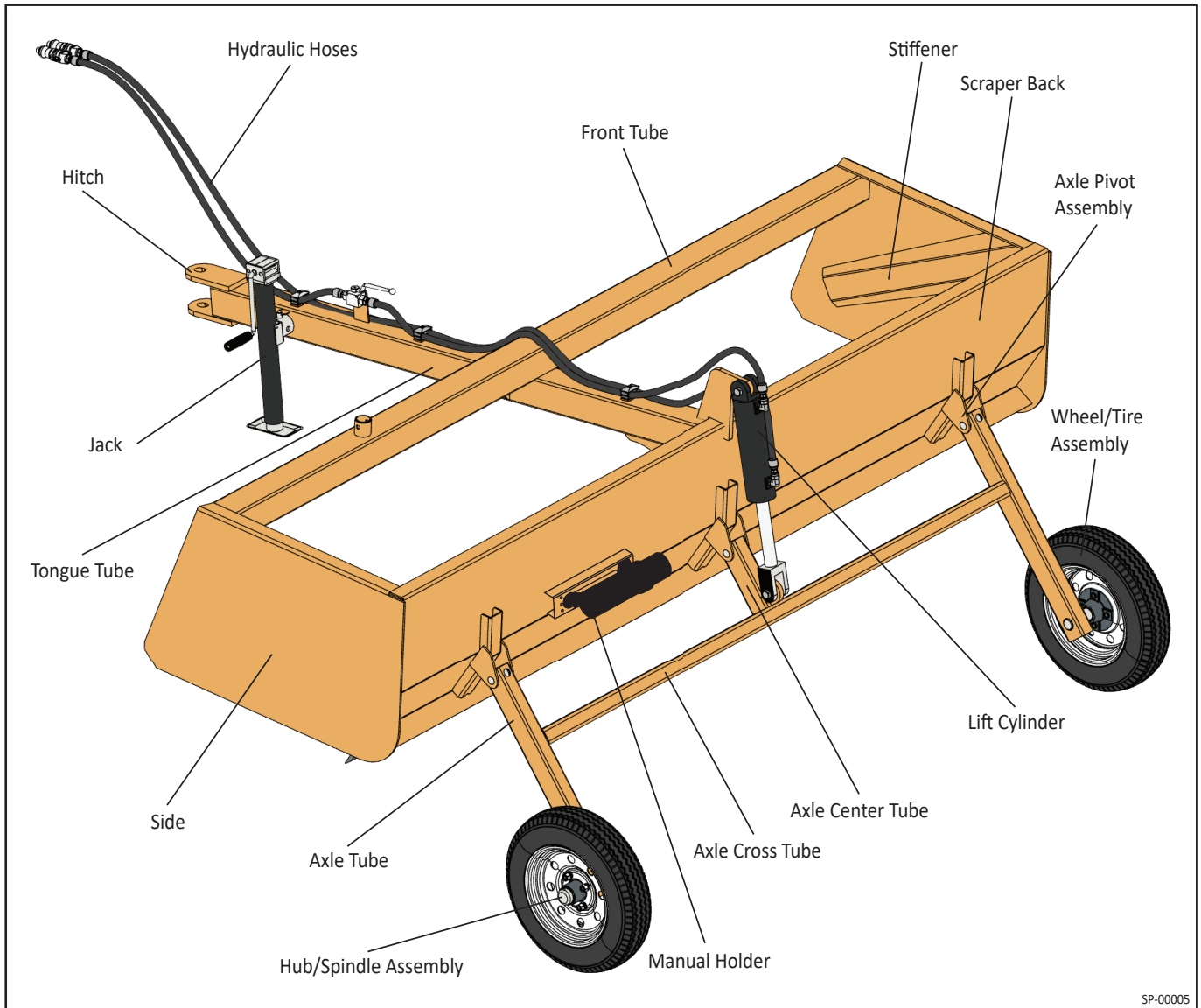

## GP Scraper Main Features Identification

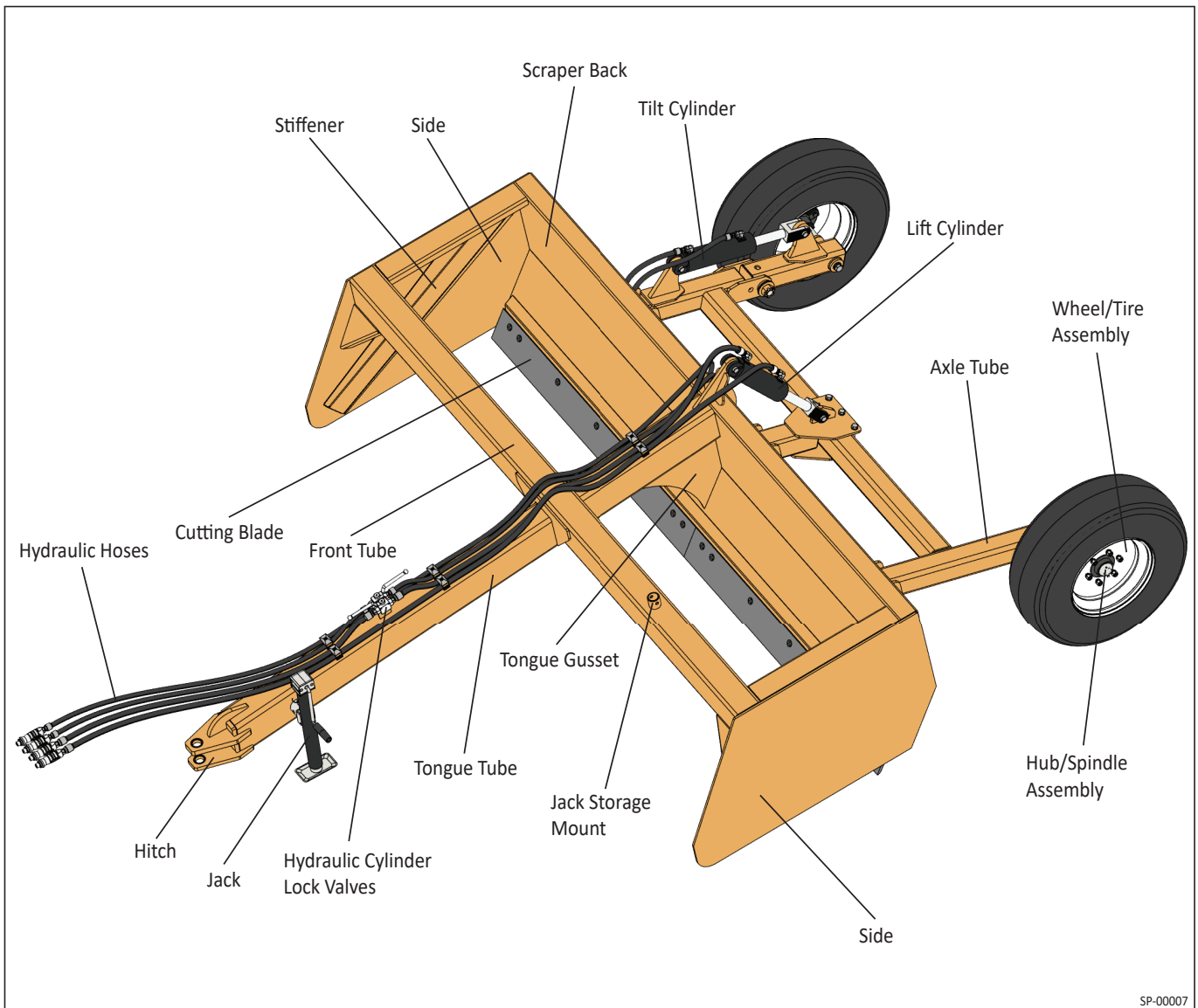

SP-00007

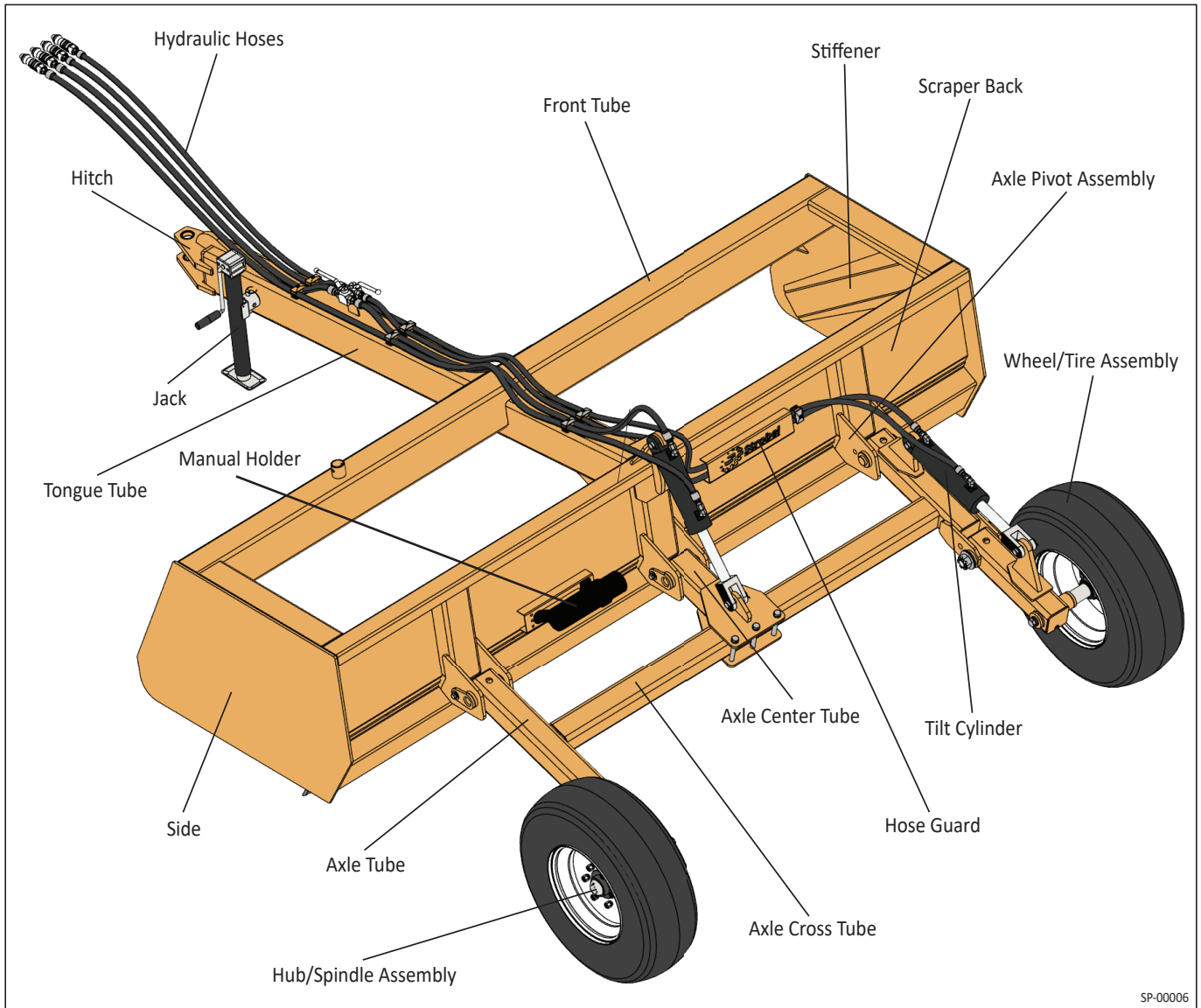

SP-00006

## MD Scraper Main Features Identification

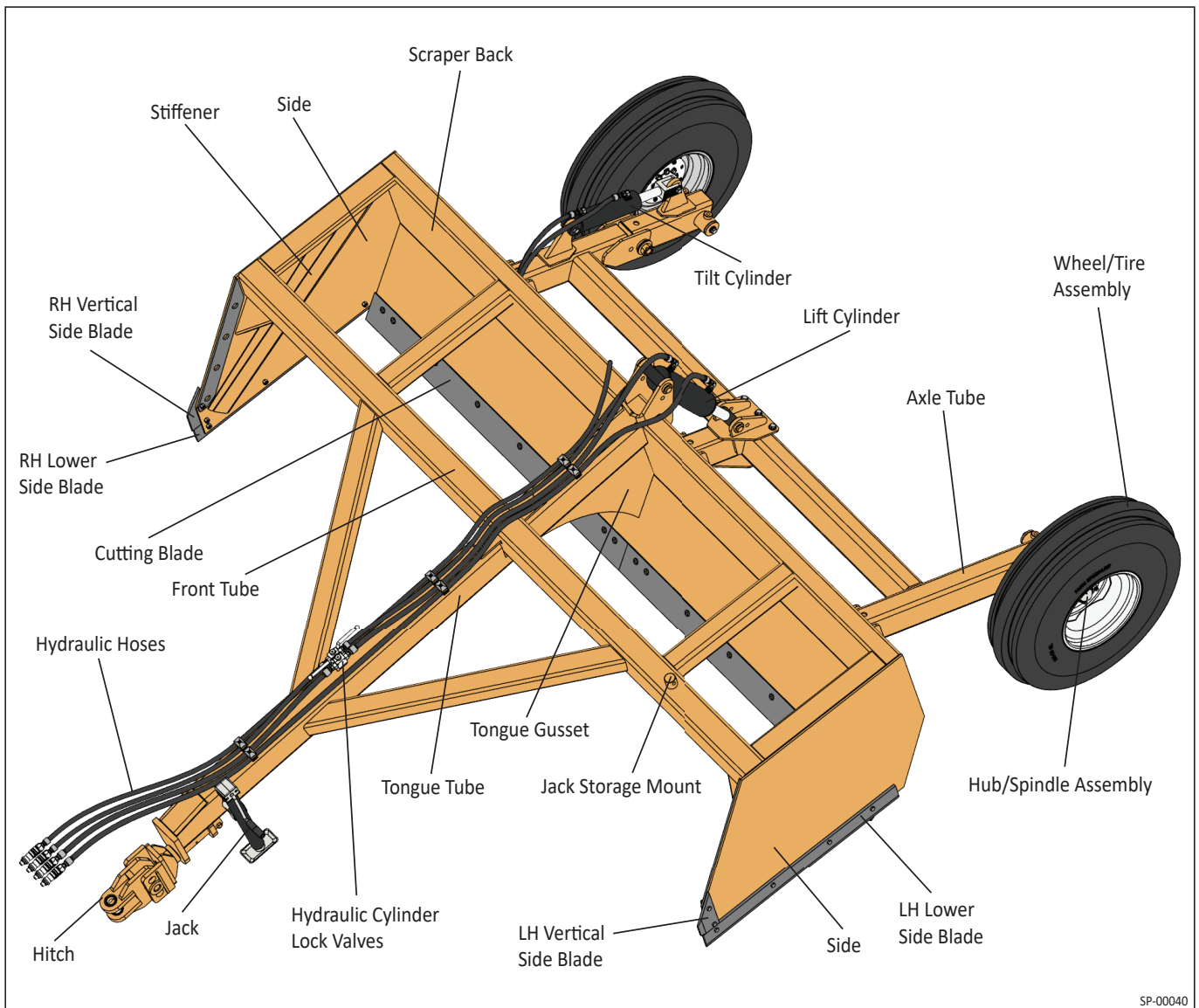

SP-00040

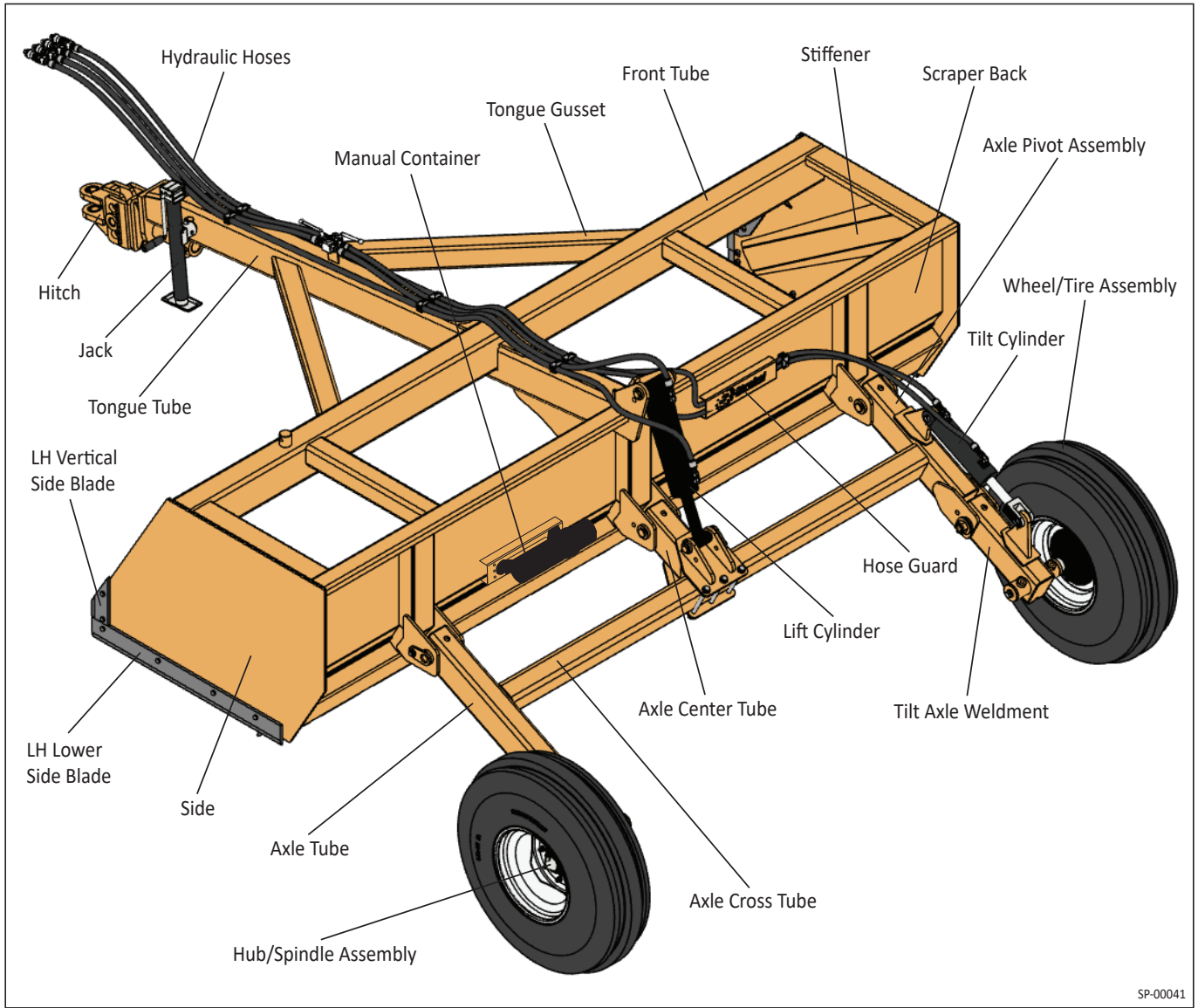

SP-00041

**MD Dual Wheels Assembly Option**

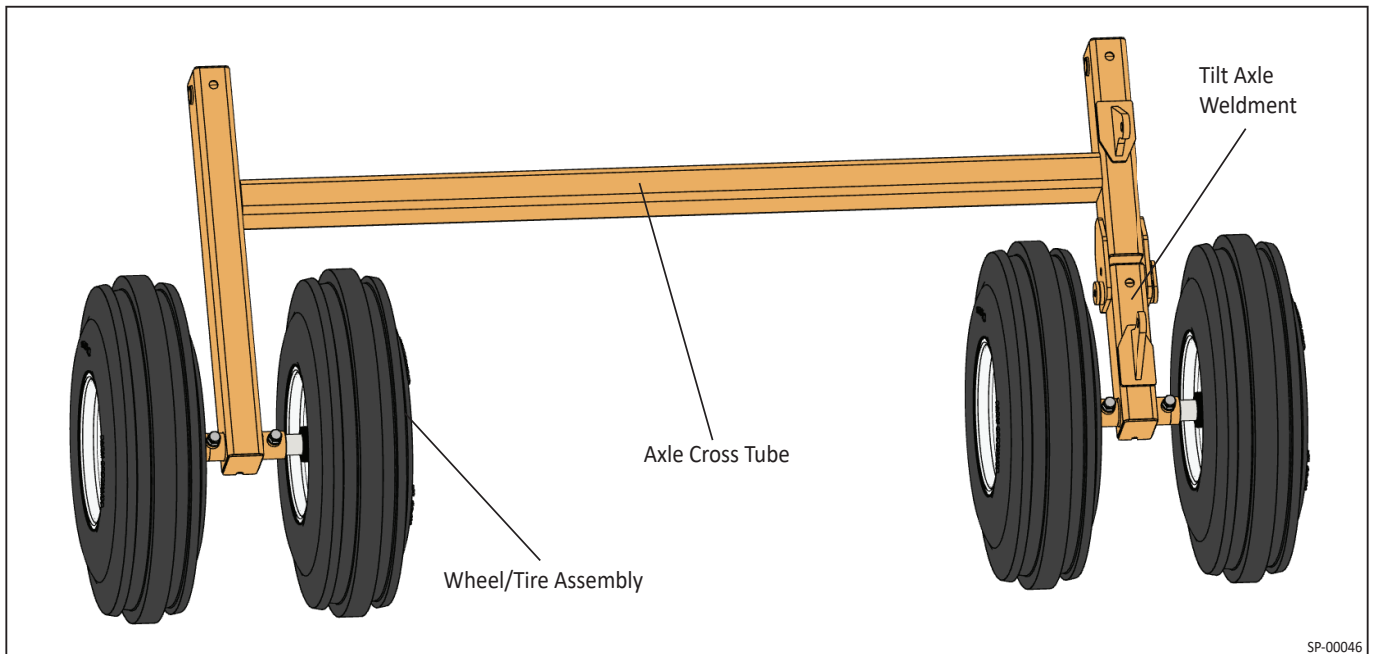

SP-00046

## Hitch Assemblies

### Note

All GP, and MD hitches are designed to work with a tilt axle. Assemblies denoted with a ^ are standard.

### LD Scrapers Non-Removable Hitch Assembly ^

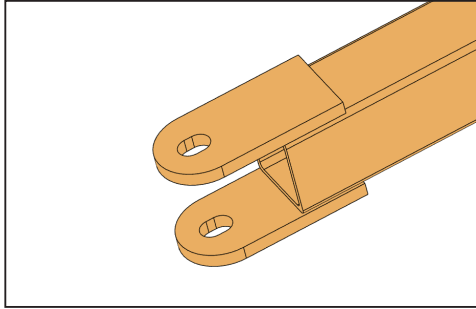

### GP Scrapers Non-Removable Hitch Assembly ^

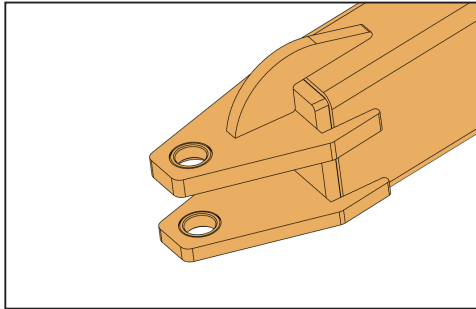

### MD Scrapers Hitch Assemblies

1-1/2" Pin, Clevis Hitch, 08031000^

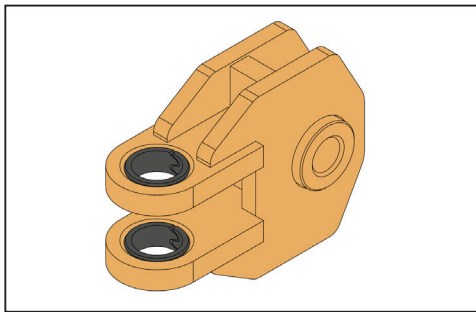

1-1/2" Hammer Strap Hitch, 08190016

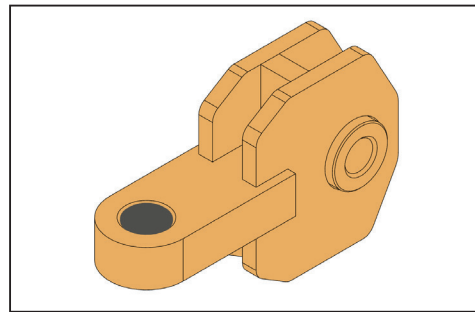

2" Hammer Strap Hitch, 08190017

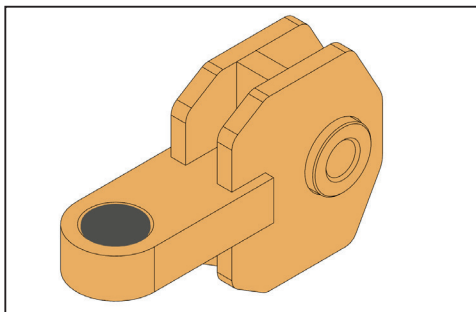

2" Clevis Hitch, 08190050

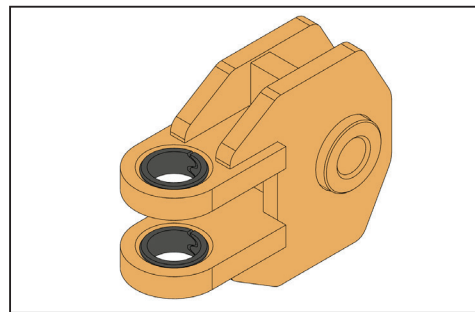

## Scraper Specifications

Model Number	Part Number	Overall Length ft in   in (mm)	Approximate Width ft in   in (mm)	Overall Weight lb (kg)	Capacity cu yd (m <sup>3</sup> )	HP Required
<b>Light Duty Box Models (LD)</b>						
LD 6	19009728	9' 11"   119" (3022)	6'   72" (1829)	735 lb (333)	1.5	25–75
LD 8	19009724	9' 11"   119" (3022)	8'   96" (2438)	980 lb (445)	2	25–100
LD 10	19009725	9' 11"   119" (3022)	10'   120" (3048)	1225 lb (556)	2.25	25–100
<b>General Purpose Models (GP)</b>						
GP 8	19009708	13' 6-1/2"   162-1/2" (4128)	8'   96" (2438)	2050 lb (930)	2.25	80–125
GP 10	19009709	13' 6-1/2"   162-1/2" (4128)	10'   120" (3048)	2350 lb (1066)	2.75	100–150
GP 12	19009710	13' 6-1/2"   162-1/2" (4128)	12'   144" (3658)	2650 lb (1202)	3.3	125–175
<b>Medium Duty Models (MD)</b>						
MD 8	19009726	16' 0"   192" (4877)	8'   96" (2438)	2500 lb (1134)	3	100–150
MD 10	19009703	16' 0"   192" (4877)	10'   120" (3048)	3000 lb (1361)	3.5	125–175
MD 12	19009701	16' 0"   192" (4877)	12'   144" (3658)	3500 lb (1588)	4	150–200
MD 14	19009706	16' 0"   192" (4877)	14'   168" (4267)	3900 lb (1769)	4.5	175–275

## Preparation

### Preparing the Tractor

- Choose a tractor of appropriate size for pulling the scraper. Greater pulling capacity is required when working in extreme or wet conditions. Choose a tractor with sufficient braking and control to pull a fully loaded scraper. Check the tractor manual or check with your tractor dealer to obtain the allowable limits for the tractor.
- The minimum tractor hydraulic system must have a 20 gal/min flow rate and be able to generate 2500 lb/in<sup>2</sup> pressure. Make sure there's enough fluid in the tractor hydraulic reservoir.
- Always follow all tractor instructions, including instructions for operation, tire inflation, wheel adjustments, weights, connecting the tractor to an implement, and hydraulics.
- Make sure the tractor drawbar is sufficient to tow the implement, and make sure it is secured into position.
- Check that the tractor three-point linkage is secure so it cannot swing and damage the tractor tires or hydraulic hoses when moving the implement.
- Make sure the hitch pin is secure and properly locked.
- Make sure all brakes are working.
- Make sure all lights are working, and check that all safety lights, reflectors, and signs are in place.

### Purging Air From the Hydraulic System

#### **WARNING**

- Always relieve all hydraulic system pressure before disconnecting from the tractor hydraulic system, making any adjustments, or performing maintenance on the hydraulic system.
  - Remove all persons and objects from the area surrounding the hydraulic system.
  - Tighten all connections before applying pressure.
1. Refer to the hydraulic power source (tractor) manual.
  2. Refill the tractor hydraulic reservoir tank if needed.
  3. Only bleed one cylinder or hydraulic circuit at a time.
  4. Pressurize the cylinder until the cylinder is fully extended. Leave the cylinder fully extended for a few minutes.
  5. Depressurize the cylinder until it fully retracts.
  6. Repeat steps 3 and 4 above 6–10 times.
  7. Make sure each hydraulic cylinder is able to fully extend and retract.

## Preparing the Jack Assembly

Jack in the Parked Position

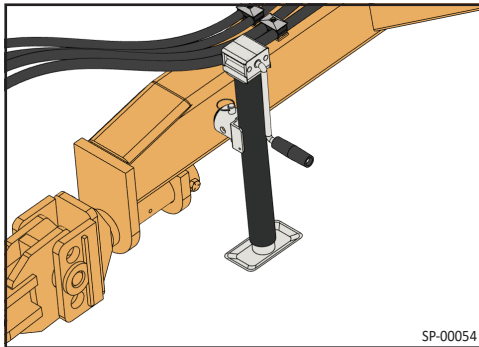

Jack in the Transport Position

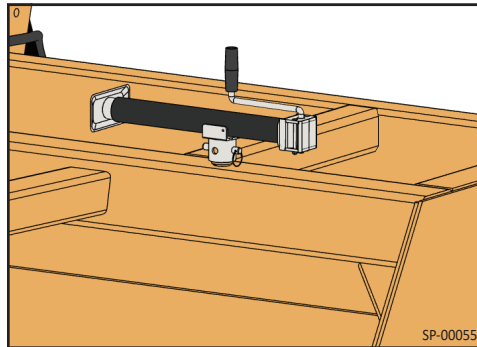

1. Remove the jack assembly from the jack mount.

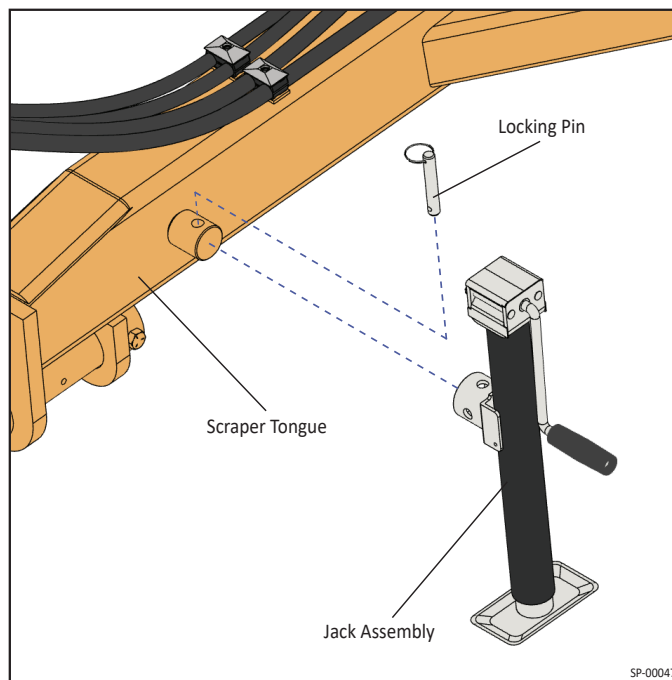

2. Securely attach the jack to the transport mount.

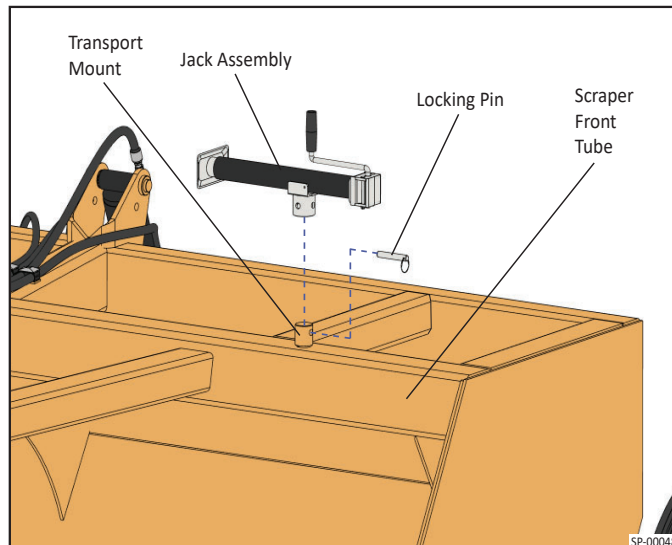

## Turning the Hydraulic Cylinder Lock Valve ON or OFF

### WARNING

- Always relieve all hydraulic system pressure before disconnecting from the tractor hydraulic system. Always relieve pressure before making adjustments to or performing maintenance on the hydraulic system.
- Prevent the hydraulic lock valve handle from unintentional turning.

### Important

Always fully open or fully close the ball valve. Handle movement is limited to 90 degrees. Leaving the valve partially opened or partially closed can cause valve deformity or damage.

1. OPEN and turn ON the hydraulic lock valve to allow the tractor hydraulic system to engage the scraper hydraulic circuit.
2. To OPEN the valve, turning the valve ON:  
Turn the valve handle counterclockwise until it is in line with the valve body centerline in the fully open position or on position.
3. CLOSE and turn OFF the hydraulic lock valve to: disengage the scraper hydraulic circuit from the tractor hydraulic system, maintain scraper hydraulic circuit equilibrium, and maintain the current position of the hydraulic cylinder in the affected hydraulic circuit.
4. To CLOSE the valve, turning the valve OFF:  
Turn the valve handle clockwise until it is 90 degrees from the valve body centerline in the fully closed or off position.

OPEN and turn ON the hydraulic lock valve.

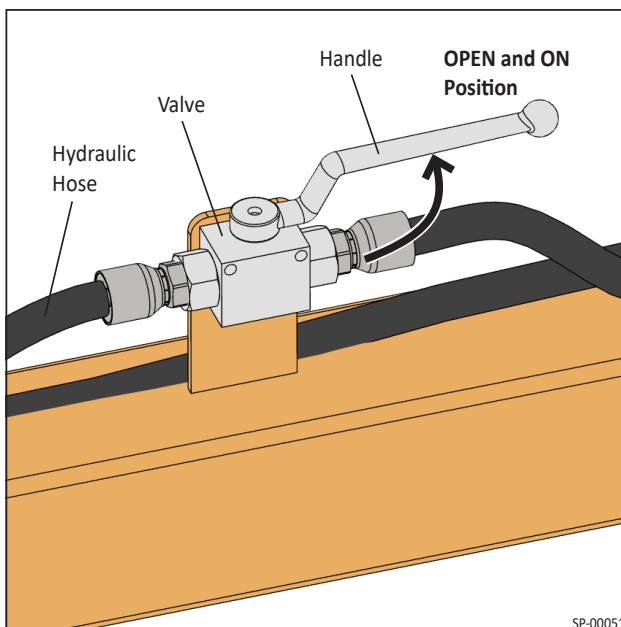

CLOSE and turn OFF the hydraulic lock valve.

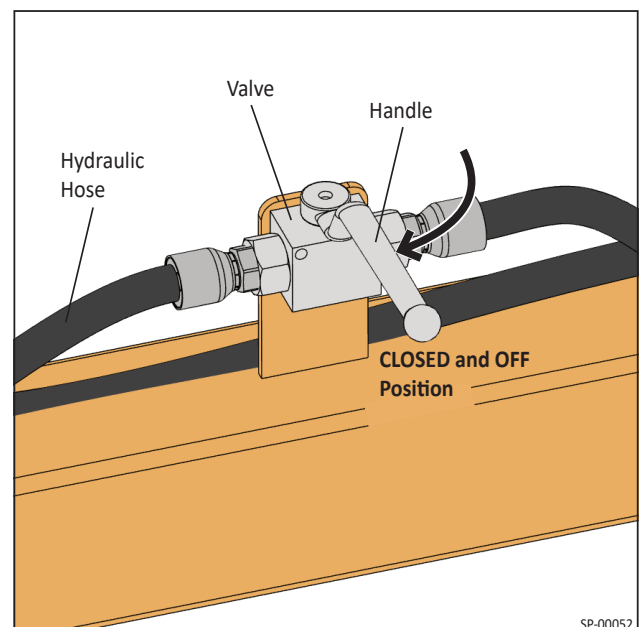

## Hitching/Unhitching the Implement

### WARNING

- Relieve all hydraulic pressure and turn off the hydraulic lock. Prevent the hydraulic lock valve handle from unintentional turning.
- Make sure both the tractor and implement are: stopped, cannot move, and resting on solid, level ground.
- Make sure the assistant guiding the tractor to the implement hitch is at a safe distance from the tractor and implement.

### Moving the Tractor Into Position

1. Lower the tractor drawbar so the scraper frame will be level when scraping.
2. Using hand signals, the assistant should direct the operator to slowly reverse the tractor to meet with the hitch.
3. When backing up the tractor reduce the throttle to the slowest idle.
4. When the tractor and the implement are in position for connecting, put the tractor in park, apply the emergency brake, shut off the tractor, remove the key, and exit the tractor.

### Hitching the Implement to the Tractor

1. Securely connect the implement hitch to the tractor drawbar.

#### **Important**

If equipped with an adjustable hitch, adjust the hitch up or down, keeping the scraper side level with the ground during blade cutting. Level operating reduces blade and implement wear.

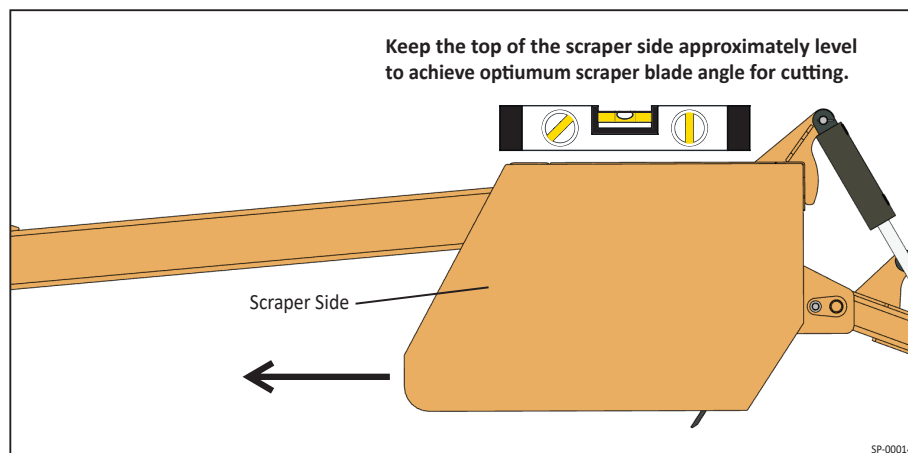

2. Apply the hitch lock.
3. If you are preparing to operate the scraper, connect the implement hydraulic fittings to the tractor hydraulic circuit.

#### **Important**

Always connect the hydraulics to the tractor in a level, brightly lit area with no bystanders or other equipment operating.

## Checking the Implement Before Operating or Transporting

### WARNING

- 
- Perform the checks in this manual section before operating or transporting.
  - Before inspecting the implement and tractor, and before connecting the implement to the tractor, make sure the implement and tractor are in a stopped position, the tractor is shut off, the tractor parking brake is on, and there is no possible way either could move.
  - Make sure tractor drawbar, hitch, hitch pins, and safety locks are all securely in place and ready for towing.
  - Make sure the implement hydraulic hoses are properly connected to the tractor hydraulic couplers and that hoses are routed properly and can't be kinked or damaged during towing.
- 

### Verify the Equipment is Ready for Operation or Transport

- Check all hardware for tightness.
- Make sure the implement is properly lubricated as indicated in “Lubrication Guide and Schedule” on page 42.
- Check for correct tire pressure. See “Checking for Proper Tire Pressure” on page 43.
- Check there is enough tractor hydraulic oil; add more if needed.

### CAUTION

---

Make sure lug nuts are tight. Improperly torqued implement lug nuts can cause a loss of implement control potentially causing an accident or leading to machine damage.

---

### Visually Inspecting Before Operation or Transport

Visually inspect the entire implement, tractor and surrounding area completely to make sure each is ready for operation or transport.

- Check for any damage caused to the implement or blades, and replace any damaged parts or blades before operating.
- Check all pins are in place, in good condition, and are tight. Replace any worn, damaged, or missing pins. Make sure all pins have cotter pins and washers.
- Check that the hydraulic cylinders are locked in position.
- Make sure the jack is securely attached to the jack storage mount before operating or transporting the implement.

## Preparing the Hydraulics Before Operating

### WARNING

Relieve hydraulic pressure and shut down the tractor immediately if there is a hydraulic failure or leak.

1. Check all hydraulic hoses and fittings for leaks. Hoses should not be twisted, damaged, or worn. Replace hoses as required. Check hose clamps and straps are in place and in good condition.

#### Note

If there are any pipe thread fittings on your implement, only use specified thread sealants.

2. Check the tractor hydraulic oil level; add oil if needed.
3. Connect the hydraulics to the tractor hydraulic banks.

#### Recommendation

Connect the lift cylinder hydraulic quick couplers to one tractor bank so when the control/lever for that bank is:

- pushed forward the entire blade lowers (lift cylinder retracts)
- pushed back the entire blade raises (lift cylinder expands)

Connect the tilt cylinder hydraulic quick couplers to one tractor bank so when the control/lever for that bank is:

- pushed forward the scraper tilt side lowers (tilt cylinder retracts)
- pushed back the scraper tilt side raises (tilt cylinder expands)

4. Before moving from the hitching site, check that the control/lever for each cylinder fully expands and retracts each cylinder.
5. View the implement while testing the hydraulics and watch for any possible hydraulic failures or leaks.

## Staying Safe on Inclines

### WARNING

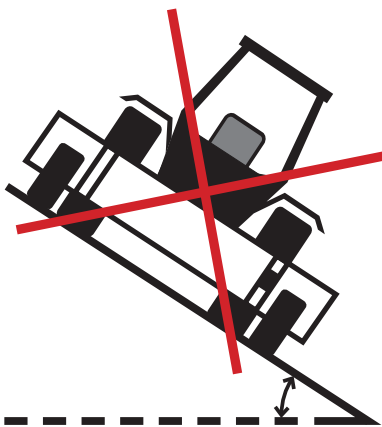

- Never put the equipment on a dangerous slope.
- Do not drive the tractor, towing vehicle, or equipment across a slope or parallel to the slope.
- Go slow, reduce engine speed, and use low gear when working on inclines, before starting downhill, or while going downhill.
- Never allow the tractor to roll down hill in neutral.
- Make sure the brakes are in proper working order before operating or working on inclines.
- Always keep your load low, know your terrain, stay alert to uneven surfaces, and prevent bouncing.
- Do not drive on inclines when weather or ground conditions such as ice, snow, rain, high winds, sand, mud, poor visibility, etc. make it unsafe.

## Transporting the Scraper

### WARNING

- 
- Read, understand, and follow the transport safety instructions in this manual's safety section before transporting this implement.
  - Be aware the implement may be wider than the tractor. Always make sure all persons, animals, buildings, and objects are clear of the implement path and work area. Prevent striking, crushing, or running over persons or obstacles.
  - Keep children, untrained persons, any others, and animals away from the implement when it is parked, operating, or moving. Never allow anyone to ride on or be on the implement.
- 

### Before Transporting

1. Before transporting the scraper, properly lock all implement locks/locking mechanisms.
2. Make sure lug nuts are tight. Improperly torqued implement lug nuts can cause a loss of implement control potentially leading to machine damage.
3. Make sure the jack is securely attached to the jack storage mount before transporting the implement.
4. Make sure the the slow moving vehicle (SMV) sign, reflectors, and safety lights are properly installed, visible, and functional.
5. Make sure any debris is unloaded and removed from the implement before transporting on public roads.
6. Raise the scraper adequately for transport.

### During Transport

### WARNING

- 
- Read and follow the safety messages in the "Operating Safety" on page 19.
  - Never exceed 20 mph (32 kph) highway transport speed or 10 mph (16 kph) off-highway transport speed to prevent roll-over.
  - Frequently check for traffic from the rear, and during turns. Check mirrors often. Use turn signal lights.
  - Reduce speed, apply caution, and allow appropriate distance when making turns or applying the brakes. Allow extra stopping distance when towing the implement.
-

## Operating the Scraper

### General Operation

#### WARNING

Do not operate on a slope greater than 4 to 1.

#### NOTICE

Do not shift to a higher gear while loading the scraper.

#### Important

- Follow the tractor instructions for operating and operating with an implement.
- Always operate the implement at a safe speed.
- If the scraper is equipped with a tilt axle, one side can be lowered more than the other. A tilt axle can be used to shape the work site or for crowning roadways.

#### Loading the Scraper

1. Choose a speed of 3–6 mph when loading the scraper. Speed reduces when the scraper is lowered.
2. When possible, load the scraper when the scraper is moving towards the dump site to achieve the shortest loaded scraper travel distance.
3. Activate the hydraulic controls and lower the blade to the ground slowly.
4. Monitor the scraper, observing it through the back window.
5. Watching the implement through the tractor window, aim to keep the top of the scraper side level with the ground.
6. Lower the blade as needed to achieve desired loading.

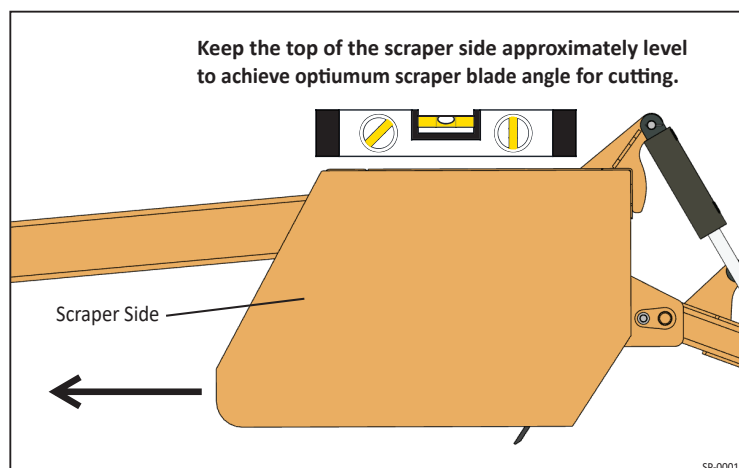

### **Unloading the Scraper**

1. After reaching the dumping area or fill site, keep the implement in a straight line.
2. Reduce the speed to no faster than 6–8 mph.
3. Activate the hydraulic remote to fully raise the blade.
4. Raise the blade quickly to achieve a pile.

### **Note**

When possible, adjust gear selection and blade clearance to unload the scraper uniformly over the unloading area or fill site.



# Maintenance

- Maintenance Safety ..... 38
- Securing and Supporting the Scraper for Maintenance ..... 38
  - Scraper Support Points ..... 39
- Bolt Torque ..... 40
- Storing the Implement..... 41
- Maintenance Schedule ..... 41
- Lubrication Guide and Schedule ..... 42
  - Back Side Lubrication Points ..... 42
  - MD Clevis Hitch Lubrication Points..... 43
- Checking for Proper Tire Pressure..... 43
- Replacing a Wheel..... 44
  - Removing a Wheel ..... 44
  - Installing a Wheel..... 44

## Maintenance Safety

### WARNING

---

*Always follow all safety instructions.*

- When working on the equipment including when lubricating the equipment, make sure both the tractor and implement are stopped, cannot move, and resting on solid, level ground.
- Make sure the scraper is fully lowered and resting firmly on the ground, or is correctly resting on jack supports.
- Make sure the work area is clean, dry, and has adequate lighting.
- Use correct parts or equivalent. Use of unauthorized parts could void the warranty. Contact the factory if in doubt.
- Always keep hands and body parts clear of pinch points.

MS-0000

## Securing and Supporting the Scraper for Maintenance

### WARNING

- 
- Follow the instructions below. Never work on or under this implement or any part of it unless it's securely positioned, blocked, and supported. Make sure when it's supported, it's blocked and supported correctly so there is no possible way this implement or any part of this implement could ever move, crush, fall on, or cut a person or any of their body parts. Always use correct jacks that will not move or fail, and which are properly rated to support the weight.

- 
1. Using the lift cylinder, safely raise the scraper rear end to full height so the lift cylinder is fully extended.
  2. Turn the hydraulic lock valves on the scraper into locked position, so the lift cylinder will remain fully extended.
  3. Make certain the tongue jack and jack supports are placed on firm, level ground.
  4. Place a jack rated for 6 US tons under each scraper support point. The correct support points are shown in the drawings that follow.
  5. Place adequate supports under the pivot gussets.

## Scraper Support Points

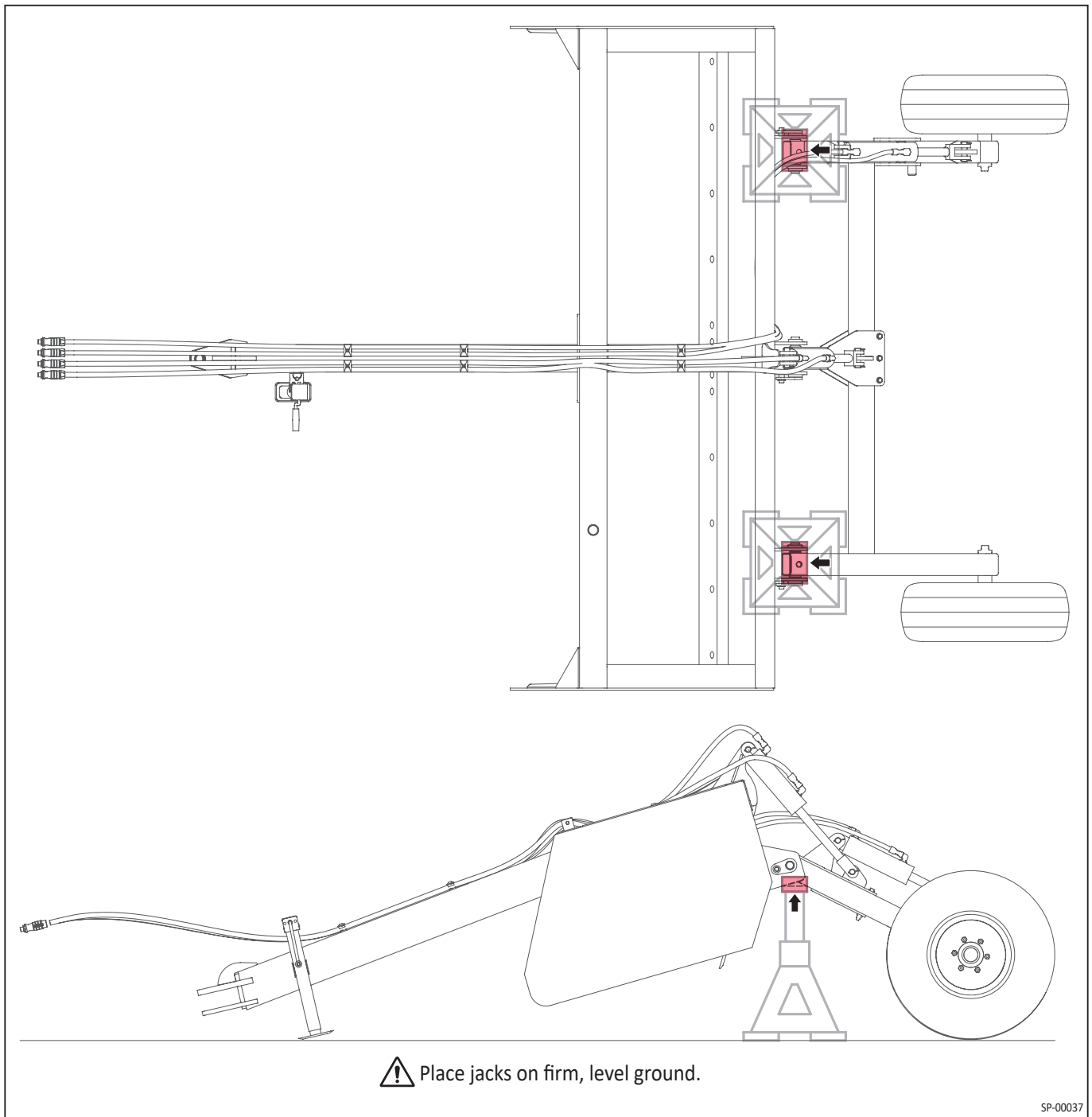

# Bolt Torque

## Bolt Grade Designation



Grade 5



Grade 8

Bolt Diameter	SAE Grade 5		SAE Grade 8	
	ft-lb	Nm	ft-lb	Nm
3/8"	35	47	50	68
7/16"	55	75	80	108
1/2"	85	115	120	163
9/16"	130	176	175	237
5/8"	170	230	240	325
3/4"	300	407	425	576
7/8"	445	603	685	929
1"	670	908	1030	1396
1-1/8"	910	1234	1460	1979
1-1/4"	1250	1695	2060	2793

## Storing the Implement

- Park the implement inside away from people and animals.
- We recommend storing it inside to protect it from moisture and rusting.

### Perform the items on this checklist before storing the implement:

1. Clean the implement removing all dirt and material to prevent rusting.
2. Check the scraper for any damaged or worn parts; make repairs and replacements as required.
3. Apply paint to any exposed metal to prevent rusting.
4. Apply grease or rust preventer to all earth moving surfaces that make contact with the material.
5. Set the implement on blocks to prevent damage to blades and to prevent tires from developing flat spots corrosion and tire damage.
6. Replace all safety decals, signs, or reflectors that are no longer easily visible and readable.

## Maintenance Schedule

Maintenance Task	Task Frequency
Check for any missing safety decals or signs.	Before each use
Clean the implement and protect exposed surfaces.	After each use
Check for and make any needed repairs, part replacements, or hose replacements.	After each use
Lubricate the Implement	Follow the Lubrication Guide and Schedule
Check tire air pressure and inflate if needed.	At least once a week.
Repaint any exposed metal.	Whenever you notice scratches, chips, or rust
Check pin bolts at all pivot locations.	Whenever there is any visible slack around pins
Grease all grease points.	After every 8 hours of use
Check wheel lug nuts for proper torque.	After every 50 hours of use

## Lubrication Guide and Schedule

Lubricate all grease fittings using an SAE multi-purpose grease.

### Back Side Lubrication Points

Lube Point	Description	Qty	Frequency
A	Bushing Grease Zerk	1 Shot	Weekly
B	Bushing Grease Zerk	1 Shot	Weekly
C	Bushing Grease Zerk	1 Shot	Weekly
D	Bushing Grease Zerk	1 Shot	Weekly
E	Hub Bearings	Repack	Once each season
F	Hub Bearings	Repack	Once each season

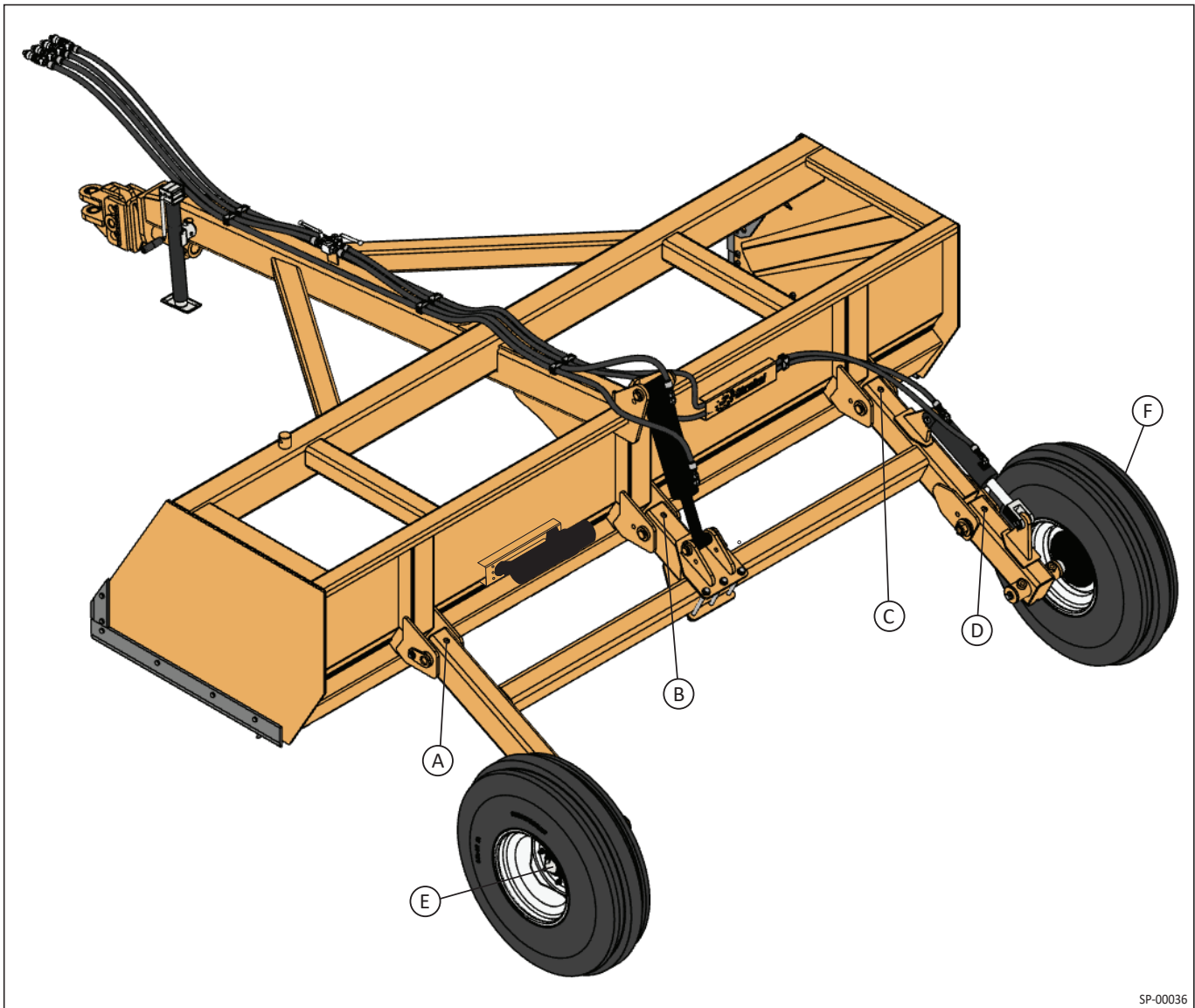

SP-00036

## MD Clevis Hitch Lubrication Points

Lube Point	Description	Qty	Frequency
A	Bushing Grease Zerk	1 Shot	Weekly
B	Bushing Grease Zerk	1 Shot	Weekly

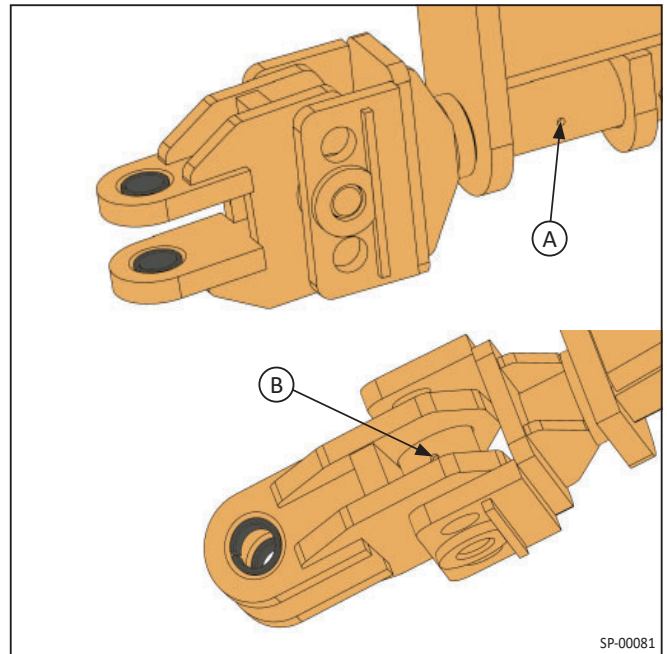

## Checking for Proper Tire Pressure

1. Perform regular tire pressure checks; once a week is recommended.
2. Find the tire PSI correct for these tires on the tire sidewall.
3. To get an accurate reading, check the tire pressure when the tires are cold.
4. Use proper tire pressure and don't exceed the maximum recommended tire pressure indicated on the tire sidewall.

### Note

- The tire should remain vertical with no sidewall sagging as the tire rolls.
  - If your tires lose more than two pounds per square inch (2 PSI) (14 kPa) per month, the tire, the valve, or wheel may be damaged. Consult your tire dealer for an inspection.
5. Use valve caps to keep valve core cleats, clear of debris and to help guard against air leakage.

# Replacing a Wheel

## Removing a Wheel

1. Park the implement on firm, level ground and make sure there's no possible way for it to move.
2. Move the tractor so it is away from the implement.
3. Shut off the tractor, apply the tractor parking brake, and make sure there is no possible way for it to move.
4. Unhitch the tractor and implement.
5. Properly raise the scraper and place it on supports. Follow the "Securing and Supporting the Scraper for Maintenance" instructions starting on page 38.
6. Remove the implement wheel assembly.

## Installing a Wheel

1. Check the parts list and ensure all parts are available. If any parts are missing contact Strobel Manufacturing.
2. Do not remove the original implement lug nuts.
3. Clean the wheel and rim and remove all dirt, debris, and grease with an appropriate cleaner.
4. Align the wheel holes with the studs, and place the wheel onto the hub studs.
5. Install lug nuts onto the two hub studs.
6. Use an appropriate installation tool to tighten lug nuts. Do not use power tools for installation.
7. Follow the appropriate tightening sequence below, finally tightening the lug nuts to the proper torque.

### 4, 6, and 8 Bolt Wheel Lug Nut Tightening Patterns

4 Lug Tightening Pattern

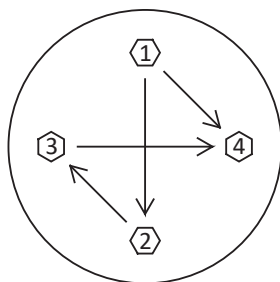

6 Lug Tightening Pattern

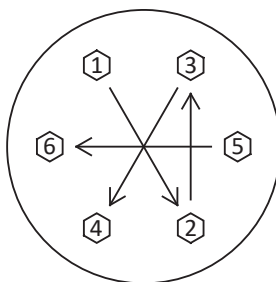

8 Lug Tightening Pattern

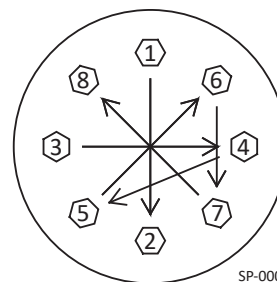

SP-00015

### Lug Nut Recommended Torque Values

Lug Nut Size	Lug Nut Torque Value	
	ft-lb	Nm
1/2"-20	90	122
5/8"-18	135	183



# Replacements and Parts

- Replacement and Parts Safety..... 46
- Replacing the Blades..... 47
  - Removing Blades .....47
  - Installing Blades .....47
- LD 6, 8, and 10 Models Replacement Parts..... 50
  - Spindle and Hub Assembly .....50
  - Blade/Blade Bolts, Hydraulic Cylinder, Jack Assembly, and Wheel/Tire Assembly .....51
  - Hydraulic System Replacement Parts .....52
- GP 8, 10, and 12 Models Replacement Parts ..... 53
  - Spindle and Hub Assembly .....53
  - Blade/Blade Bolts, Hydraulic Cylinder, Jack Assembly, and Wheel/Tire Assembly .....54
  - Axle Assembly .....55
  - Hydraulic System Replacement Parts .....56
- MD 8, 10, 12, and 14 Models Replacement Parts..... 57
  - Single Wheel Spindle and Hub Assembly.....57
  - Dual Wheel Spindle and Hub Assembly.....58
  - Blade/Blade Bolts, Hydraulic Cylinders, Jack Assembly, and Wheel/Tire Assembly .....59
  - Axle Assembly .....60
  - Hydraulic System Replacement Parts .....61
  - Swivel Hitch Assembly .....62

## Replacement and Parts Safety

 **WARNING**

---

*Always follow all safety instructions.*

- When working on the equipment including when lubricating the equipment, make sure both the tractor and implement are: stopped, cannot move, and resting on solid, level ground.
- Make sure the scraper is fully lowered and resting firmly on the ground, or is correctly resting on jack supports.
- Make sure the work area is clean, dry, and has adequate lighting.
- Use correct parts or equivalent. Use of unauthorized parts could void the warranty. Contact the factory if in doubt.
- Always keep hands and body parts clear of pinch points.

---

MS-0000

## Replacing the Blades

### Removing Blades

1. Set the scraper securely onto blocks.

**Important**

Make certain there is no possible way for the scraper to move or drop down off the blocks.

2. Relieve the hydraulic system pressure.
3. Disconnect all hydraulic hoses from the tractor and lock out the tractor.
4. Loosen, but don't remove all blade end bolts.
5. Remove all other blade bolts.
6. Remove end bolts and carefully lower the blade to the ground.

### Installing Blades

1. Carefully lift the new blade into position.
2. Install but don't tighten blade end bolts and nuts.
3. Loosely install the remaining blade bolts and nuts.
4. After all blade bolts and nuts are installed, tighten the bolts to proper torque.

### LD Blade Replacement

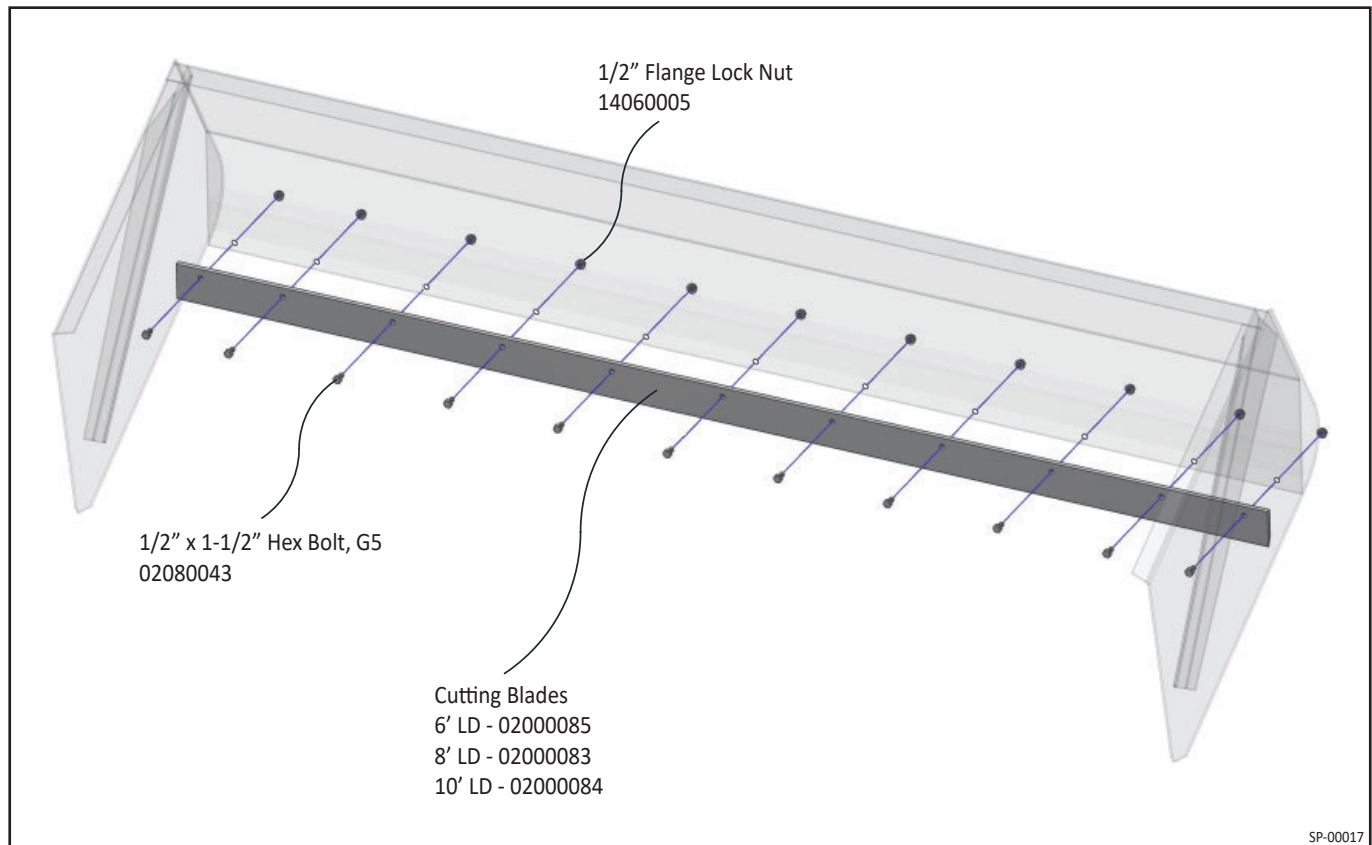

### GP Blade Replacement

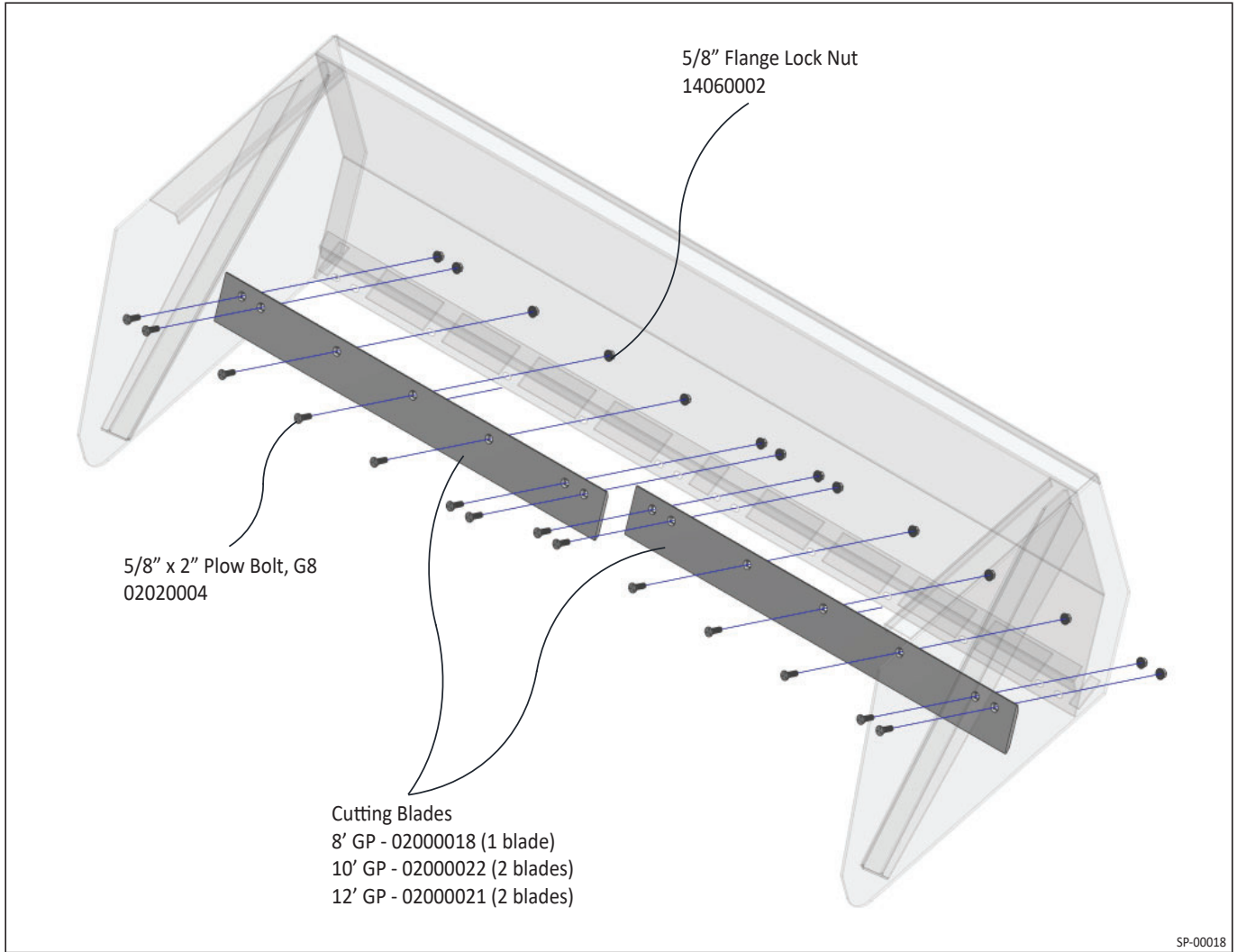

SP-00018

### MD Blade Replacement

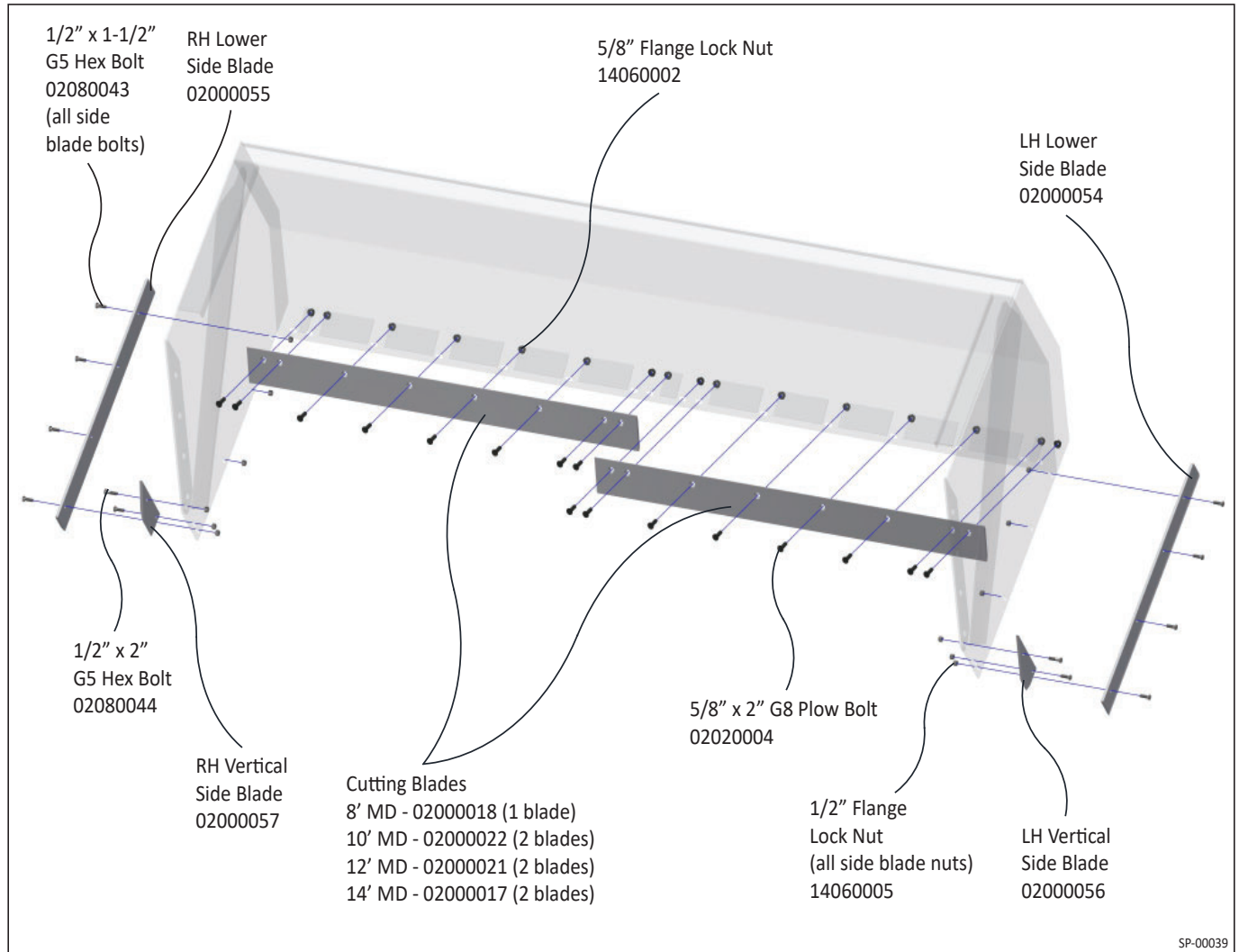

## LD 6, 8, and 10 Models Replacement Parts

### Spindle and Hub Assembly (2 per Box Scraper)

ID	Part Number	Qty	Description
1	03070001	1	Grease Cap
2	16030312	1	5/32" x 2" Cotter Pin
3	14030005	1	1"-14 Spindle Nut
4	23192011	1	1" Spindle Washer
5,10	02030065	2	Bearing Cone
6,9	02030007	2	Bearing Cup
7	14230004	4	1/2"-20 Lug Nut
8	08230004	1	4-Bolt Hub
11	19080446	1	Grease Seal
12	19080605	1	Spindle

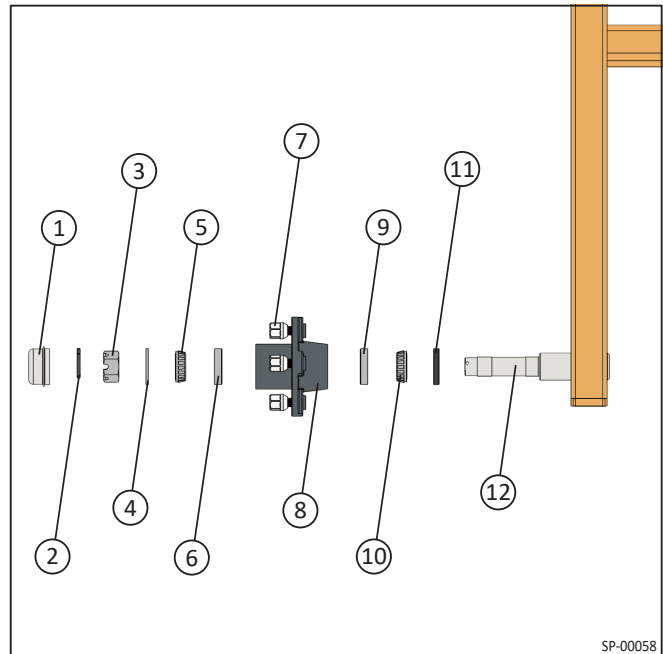

SP-00058

**Blade/Blade Bolts, Hydraulic Cylinder, Jack Assembly, and Wheel/Tire Assembly**

Blades

ID	Part Number	Qty	Description
1	02000085	1	6' LD Cutting Blade
	02000083	1	8' LD Cutting Blade
	02000084	1	10' LD Cutting Blade

Blade Nuts

ID	Part Number	Qty	Description
3	14060005	7	6' LD Blade 1/2" G8 Nut
		9	8' LD Blade 1/2" G8 Nut
		11	10' LD Blade 1/2" G8 Nut

Blade Bolts

ID	Part Number	Qty	Description
2	02080043	7	6' LD Blade 1/2" x 1-1/2" G5 Hex Bolt
		9	8' LD Blade 1/2" x 1-1/2" G5 Hex Bolt
		11	10' LD Blade 1/2" x 1-1/2" G5 Hex Bolt

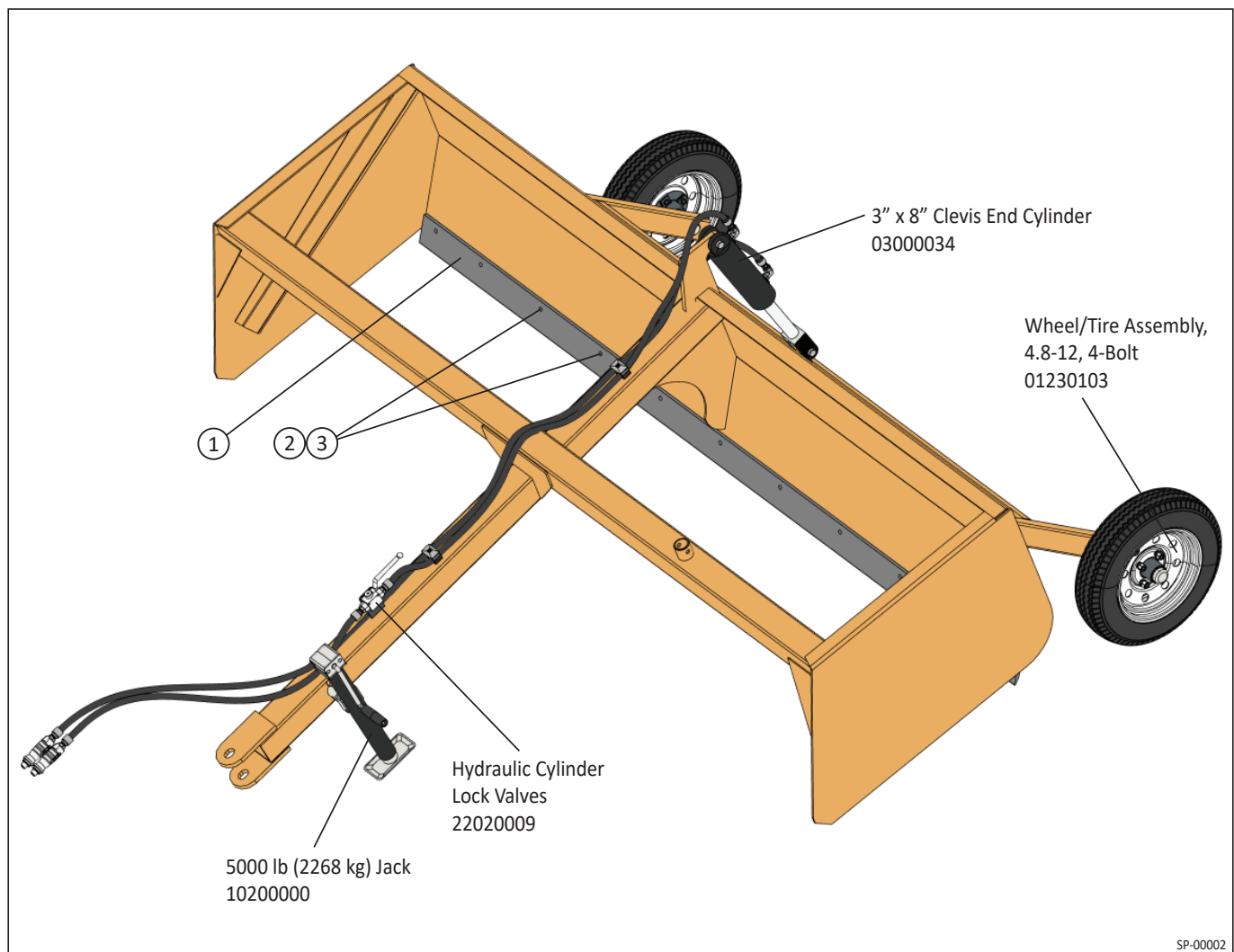

SP-00002

## Hydraulic System Replacement Parts

ID	Part Number	Qty	Description
1	03080025	2	-8 Quick Conn Coupler, 3/4 O-Ring Male
2	08180004O	1	-8 (3/4"-16) Hydraulic Handle Extend
3	08180004I	1	-8 (3/4"-16) Hydraulic Handle Retract
4	Contact Factory	1	3/8" Hyd Hose, 3/4-16 O-ring Male
5	Contact Factory	1	3/8" Hyd Hose, 3/4-16 O-ring Male, 3/4-16 JIC Female
6	22020009	2	#8 SAE Female Ball Valve
7	Contact Factory	1	3/8" Hyd Hose, 3/4-16 O-ring Male, 3/4-16 JIC Female
8	03000034	1	3" x 8" Lift Cylinder
9	05000004	2	90° Elbow, 3/4-16 JIC Male, 3/4-16 NPTF male

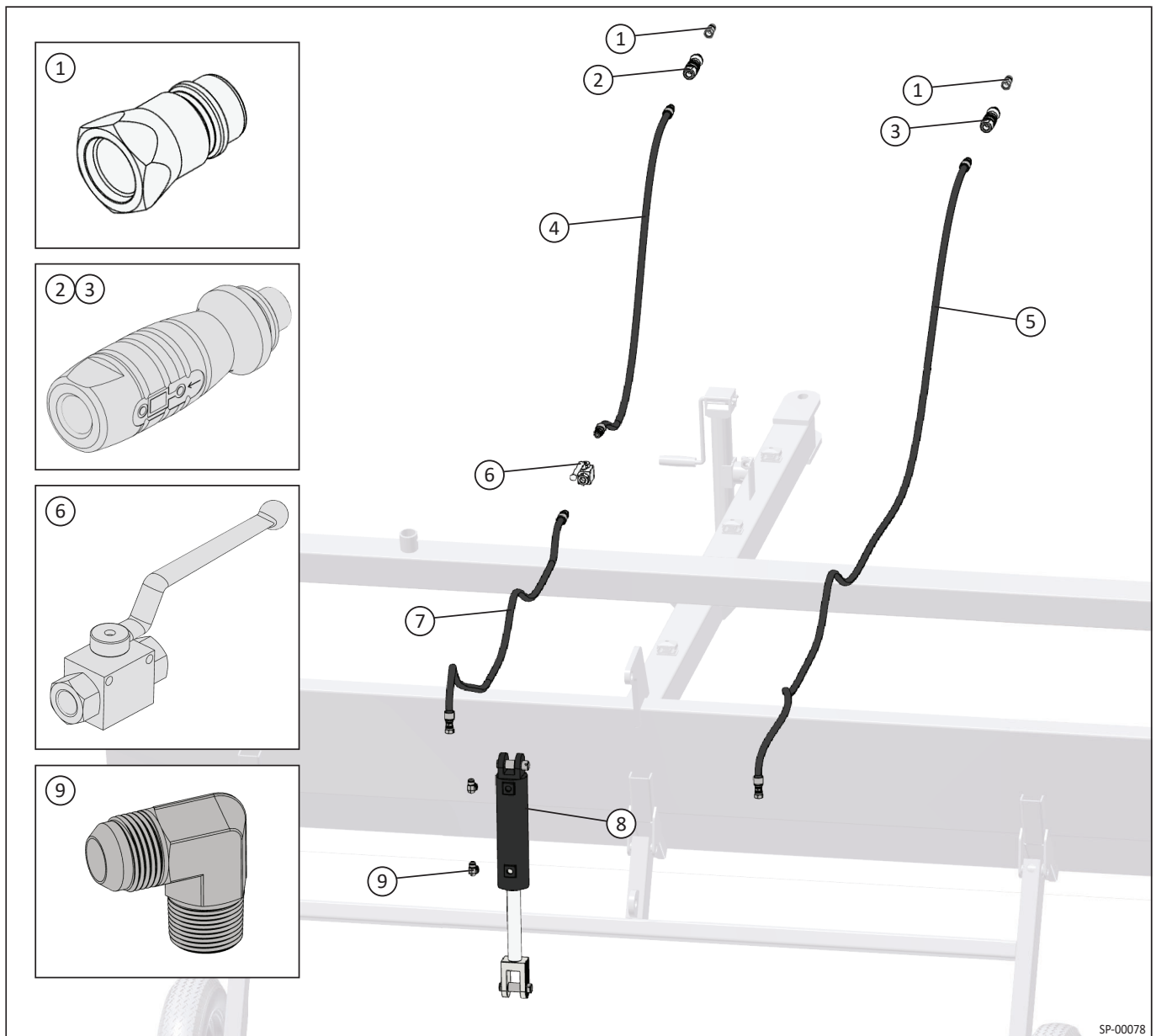

SP-00078

## GP 8, 10, and 12 Models Replacement Parts

### Spindle and Hub Assembly (2 per Box Scraper)

ID	Part Number	Qty	Description
1	03081000	1	Grease Cap
2	16030312	1	5/32" x 2" Cotter Pin
3	14030002	1	7/8" UNF Spindle Nut
4	23192000	1	7/8" Spindle Washer
5	02030013	1	Bearing Cone
6	02030012	1	Bearing Cup
7	14230004	6	1/2"-20 Lug Nut
8	08230002	1	6-Bolt Hub
9	02030023	1	Bearing Cup
10	02030024	1	Bearing Cone
11	19080405	1	Grease Seal
12	19080618	1	Spindle
13	03050004	1	Spindle Cap
14	23060006	1	3/4" Flat Washer
15	23120006	1	3/4" Lock Washer
16	02080069	1	3/4" x 2" G5 Bolt

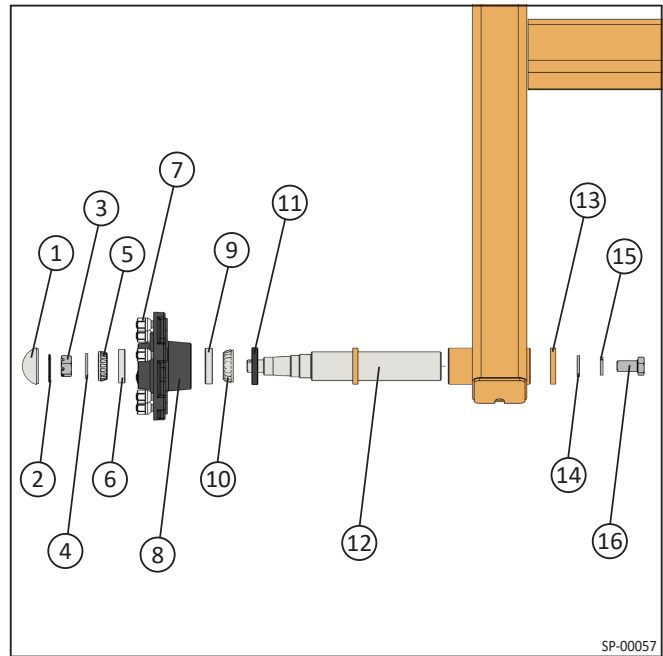

SP-00057

## Blade/Blade Bolts, Hydraulic Cylinder, Jack Assembly, and Wheel/Tire Assembly

### Blades

ID	Part Number	Qty	Description
1	02000018	1	8' GP Cutting Blade
	02000022	2	10' GP Cutting Blade
	02000021	2	12' GP Cutting Blade

### Blade Nuts

ID	Part Number	Qty	Description
3	14060002	10	8' GP Blade 5/8" Flange Lock Nut
		14	10' GP Blade 5/8" Flange Lock Nut
		16	12' GP Blade 5/8" Flange Lock Nut

### Blade Bolts

ID	Part Number	Qty	Description
2	02020004	10	8' GP Blade 5/8" x 2" Plow Bolt
		14	10' GP Blade 5/8" x 2" Plow Bolt
		16	12' GP Blade 5/8" x 2" Plow Bolt

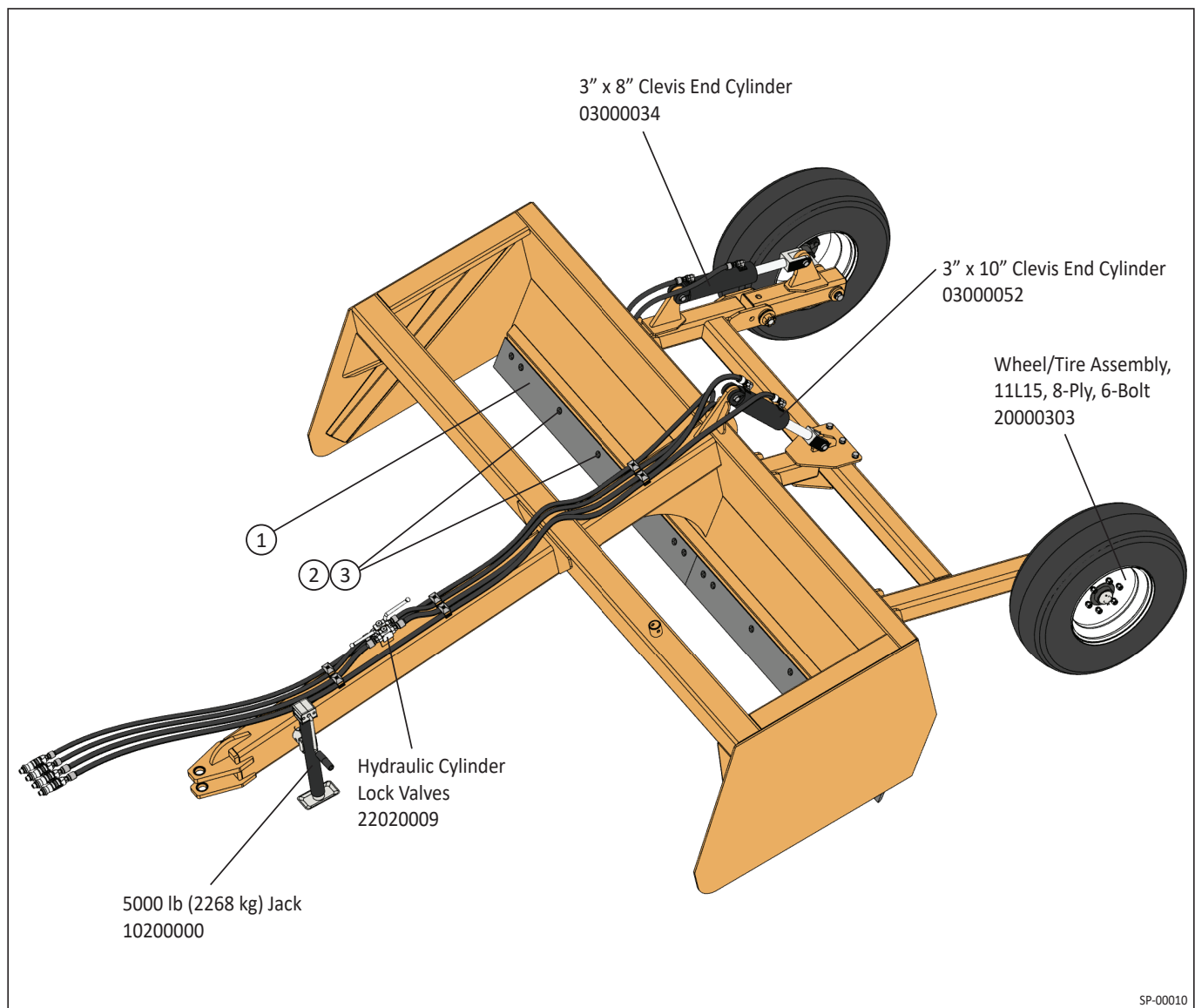

SP-00010

## Axle Assembly

### Axle

ID	Part Number	Qty	Description
1	23010067	1	8' GP Axle Assembly
	23010051	1	10' GP Axle Assembly
	23010006	1	12' GP Axle Assembly
2	23200023	1	Axle Center Tube Assembly
3	23010005	1	Tilt Axle Leg Weldment

### Axle Hardware

ID	Part Number	Qty	Description
4	16017002	3	Axle Pivot Pin
5	23160007	1	Tilt Axle Pin
6	23192007	2	1-1/4" Flat Washer
7	02080041	4	1/2" x 1" G5 Hex Bolt
8	16030310	1	1/4" x 2-1/2" Cotter Pin
9	23060005	6	5/8" Flat Washer
10	23120005	3	5/8" Lock Washer
11	14030006	1	1-1/4" Castle Nut
12	23060004	4	1/2" Flat Washer
13	23120004	4	1/2" Lock Washer
14	02080064	3	5/8" x 6" G5 Hex Bolt
15	14080005	3	5/8" Hex Nut

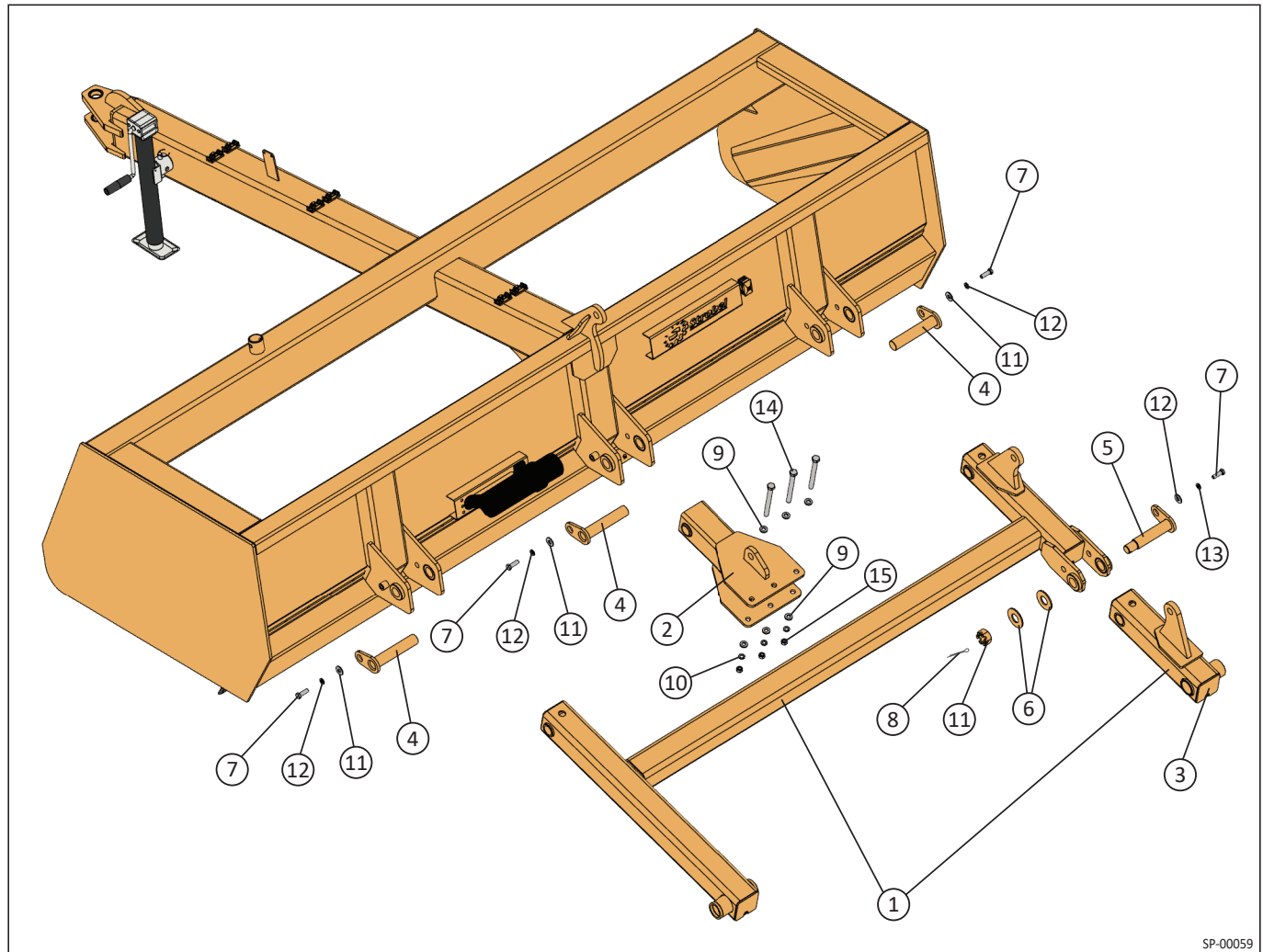

SP-00059

### Hydraulic System Replacement Parts

ID	Part Number	Qty	Description
1	03080025	2	-8 Quick Conn Coupler, 3/4 O-Ring Male
2	08180004O	2	-8 (3/4"-16) Hydraulic Handle Extend
3	08180004I	2	-8 (3/4"-16) Hydraulic Handle Retract
4	Contact Factory	1	1/2" Hyd Hose, 3/4-16 O-Ring Male, 3/4-16 JIC female
5	Contact Factory	1	1/2" Hyd Hose, 3/4-16 O-Ring Male
6	Contact Factory	1	3/8" Hyd Hose, 3/4-16 O-Ring Male
7	Contact Factory	1	3/8" Hyd Hose, 3/4-16 O-Ring Male, 3/4-16 JIC Female

ID	Part Number	Qty	Description
8	22020009	2	#8 SAE Female Ball Valve
9	Contact Factory	1	1/2" Hyd Hose, 3/4-16 O-Ring Male, 3/4-16 JIC Female
10	Contact Factory	1	3/8" Hyd Hose, 3/4-16 O-Ring Male, 3/4-16 JIC Female
11	05000004	4	90° Elbow, 3/4-16 JIC Male, 3/4-16 NPTF Male
12	03000052	1	3" x 10" Lift Cylinder
13	03000034	1	3" x 8" Tilt Cylinder

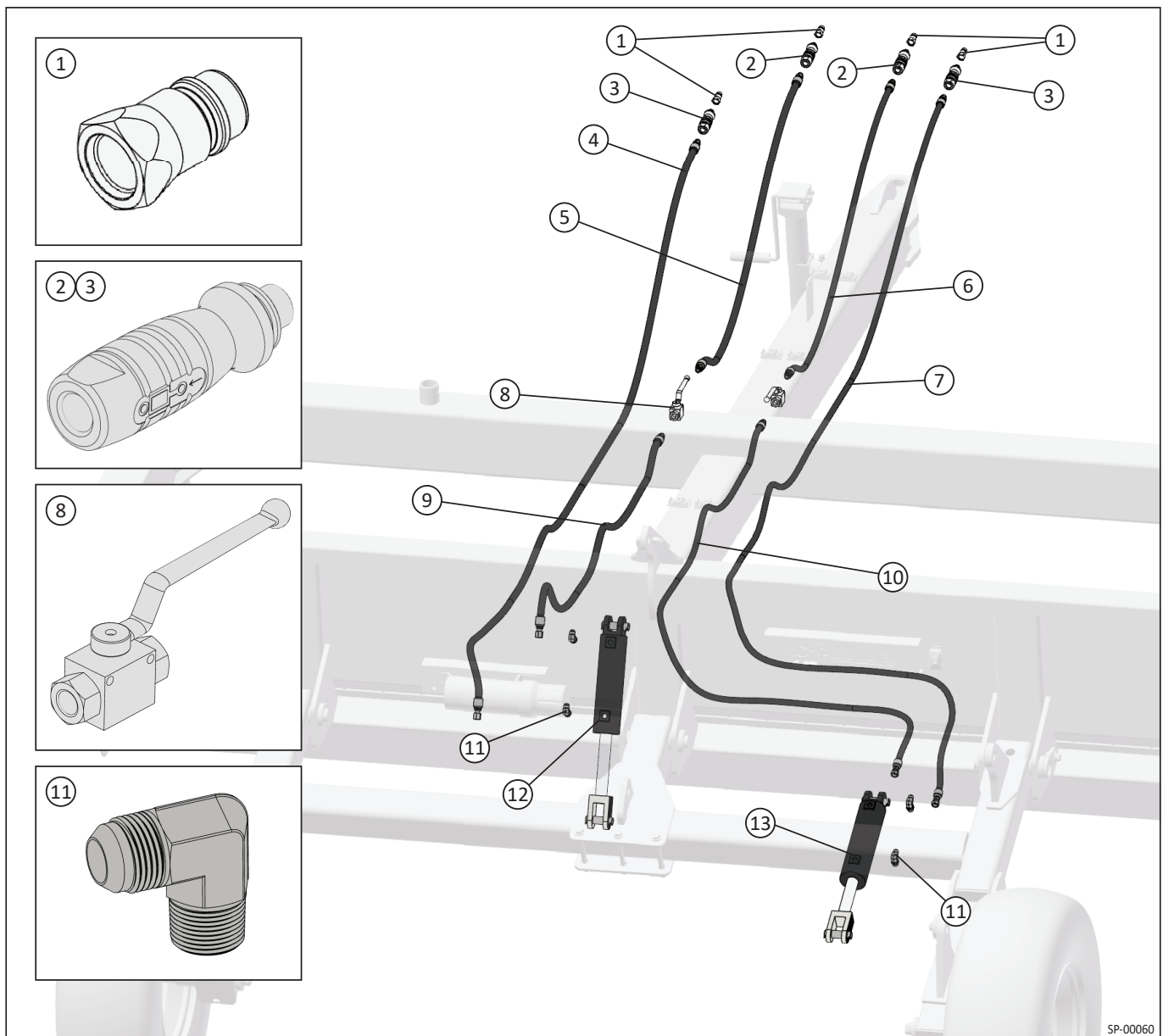

SP-00060

# MD 8, 10, 12, and 14 Models Replacement Parts

## Single Wheel Spindle and Hub Assembly (2 per Box Scraper)

ID	Part Number	Qty	Description
1	03081000	1	Grease Cap
2	16030312	1	5/32" x 2" Cotter Pin
3	14030002	1	7/8" UNF Spindle Nut
4	23192000	1	7/8" Spindle Washer
5	02030013	1	Bearing Cone
6	02030012	1	Bearing Cup
7	14230006	8	5/8"-18 Lug Nut
8	08230001	1	8-Bolt Hub, 4500 lb
9	02030014	1	Bearing Cup
10	02030015	1	Bearing Cone
11	19080403	1	Grease Seal
12	19080628	1	Spindle
13	03050004	1	Spindle Cap
14	23060006	1	3/4" Washer
15	23120006	1	3/4" Lock Washer
16	02080069	1	3/4" x 2" G5 Bolt

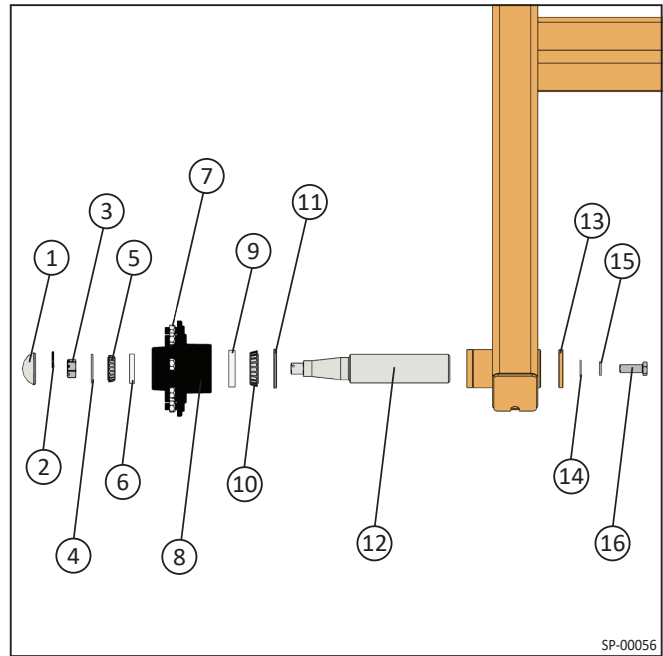

### Dual Wheel Spindle and Hub Assembly (2 per Box Scraper)

ID	Part Number	Qty	Description
1	03081000	2	Grease Cap
2	16030312	2	5/32" x 2" Cotter Pin
3	14030002	2	7/8" UNF Spindle Nut
4	23192000	2	7/8" Spindle Washer
5	02030013	2	Bearing Cone
6	02030012	2	Bearing Cup
7	14230006	16	5/8"-18 Lug Nut
8	08230001	2	8-Bolt Hub, 4500 lb
9	02030014	2	Bearing Cup
10	02030015	2	Bearing Cone
11	19080403	2	Grease Seal
12	19080620	1	Dual Wheel Spindle
13	14100013	2	3/4" G5 Locking Jam Nut
14	02080066	2	3/4" x 2-1/2" G5 Hex Bolt

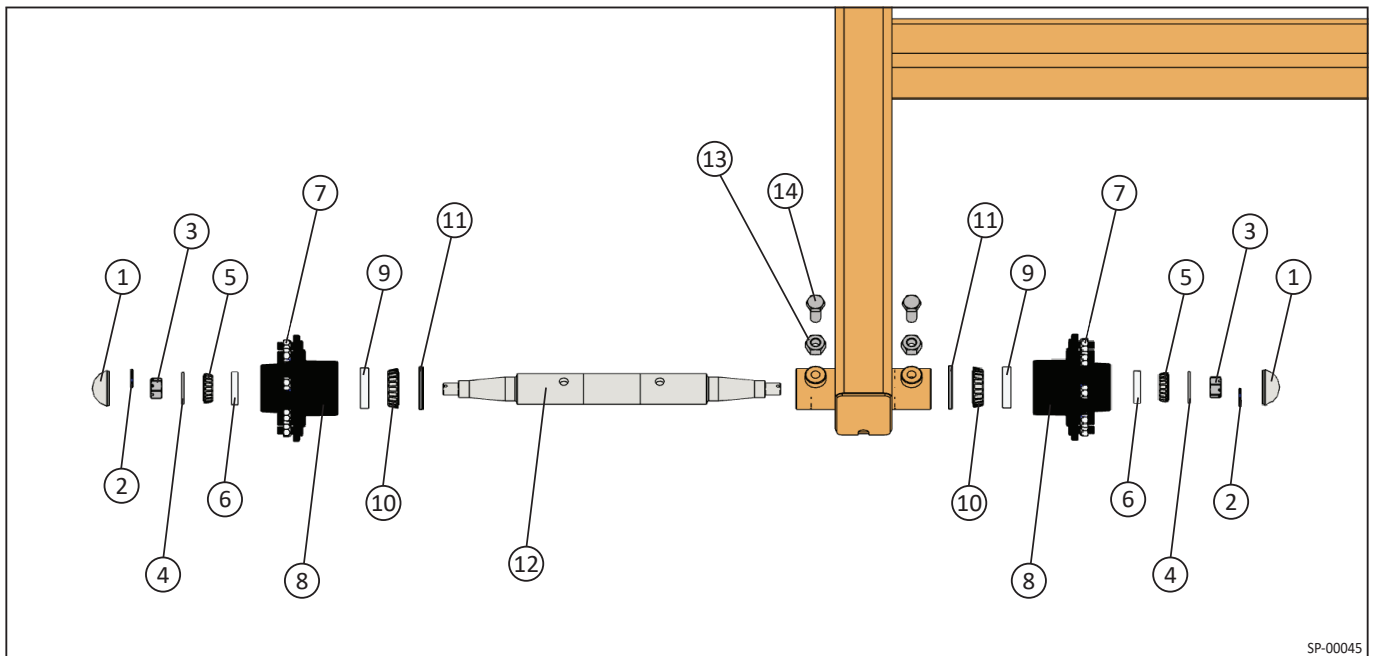

SP-00045

## Blade/Blade Bolts, Hydraulic Cylinders, Jack Assembly, and Wheel/Tire Assembly

### Blades

ID	Part Number	Qty	Description
1	02000018	1	8' MD Cutting Blade
	02000022	2	10' MD Cutting Blade
	02000021	2	12' MD Cutting Blade
	02000017	2	14' MD Cutting Blade
2	02000055	1	RH Lower Side Blade, All Models
3	02000054	1	LH Lower Side Blade, All Models
4	02000057	1	RH Vertical Side Blade, All Models
5	02000056	1	LH Vertical Side Blade, All Models

### Blade Bolts

ID	Part Number	Qty	Description
6	02020004	10	8' MD Blade 5/8" x 2" G8 Plow Bolt
		14	10' MD Blade 5/8" x 2" G8 Plow Bolt
		16	12' MD Blade 5/8" x 2" G8 Plow Bolt
		18	14' MD Blade 5/8" x 2" G8 Plow Bolt
7	02080043	10	1/2" x 1-1/2" G5 Hex Bolt
8	02080044	2	1/2" x 2" G5 Hex Bolt

### Blade Nuts

ID	Part Number	Qty	Description
9	14060002	10	8' MD Blade 5/8" Flange Lock Nut
		14	10' MD Blade 5/8" Flange Lock Nut
		16	12' MD Blade 5/8" Flange Lock Nut
		18	14' MD Blade 5/8" Flange Lock Nut
10	14060005	12	MD Side Blades 1/2" Flange Lock Nut

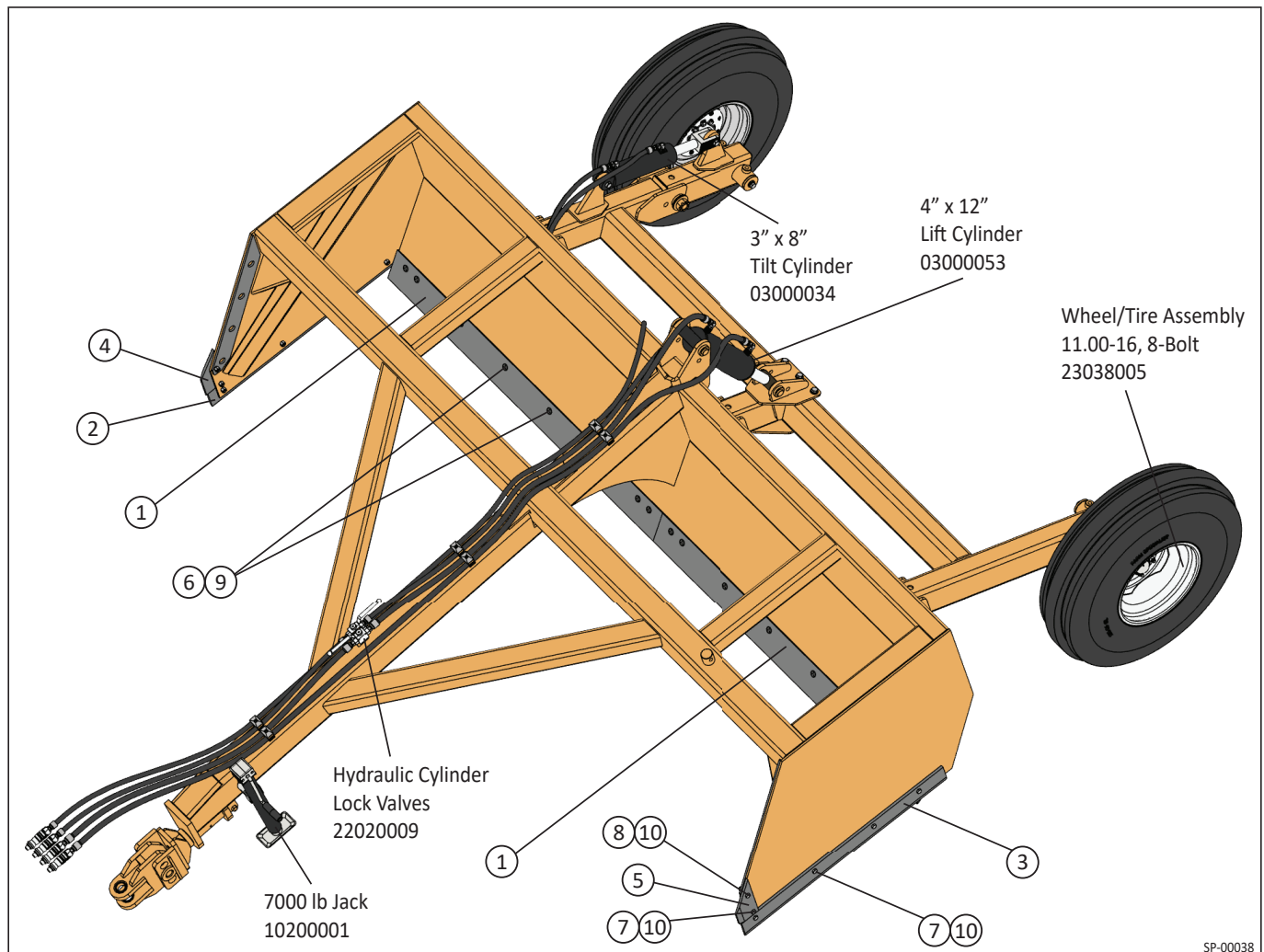

SP-00038

## Axle Assembly

### Axle

ID	Part Number	Qty	Description
1	Contact Factory	1	8' MD Axle Assembly
	23010052	1	10' MD Axle Assembly
	23010053	1	12' MD Axle Assembly
	23010054	1	14' MD Axle Assembly
2	23200024	1	Axle Center Tube Assembly
3	23010057	1	Tilt Axle Leg Weldment
^	11230002	1	MD Dual Wheel Axle Assembly (Not shown here; shown on page 25)

### Axle Hardware

ID	Part Number	Qty	Description
4	16017002	3	Axle Pivot Pin
5	23160007	1	Tilt Axle Pin
6	02080041	4	1/2" x 1" G5 Hex Bolt
7	16030310	1	1/4" x 2-1/2" Cotter Pin
8	23060005	6	5/8" Flat Washer
9	23120005	3	5/8" Lock Washer
10	23192007	2	1-1/4" Flat Washer
11	14030006	1	1-1/4" Castle Nut
12	23060004	4	1/2" Flat Washer
13	23120004	4	1/2" Lock Washer
14	02080323	3	5/8" X 8" G5 Hex Bolt
15	14080005	3	5/8" Hex Nut

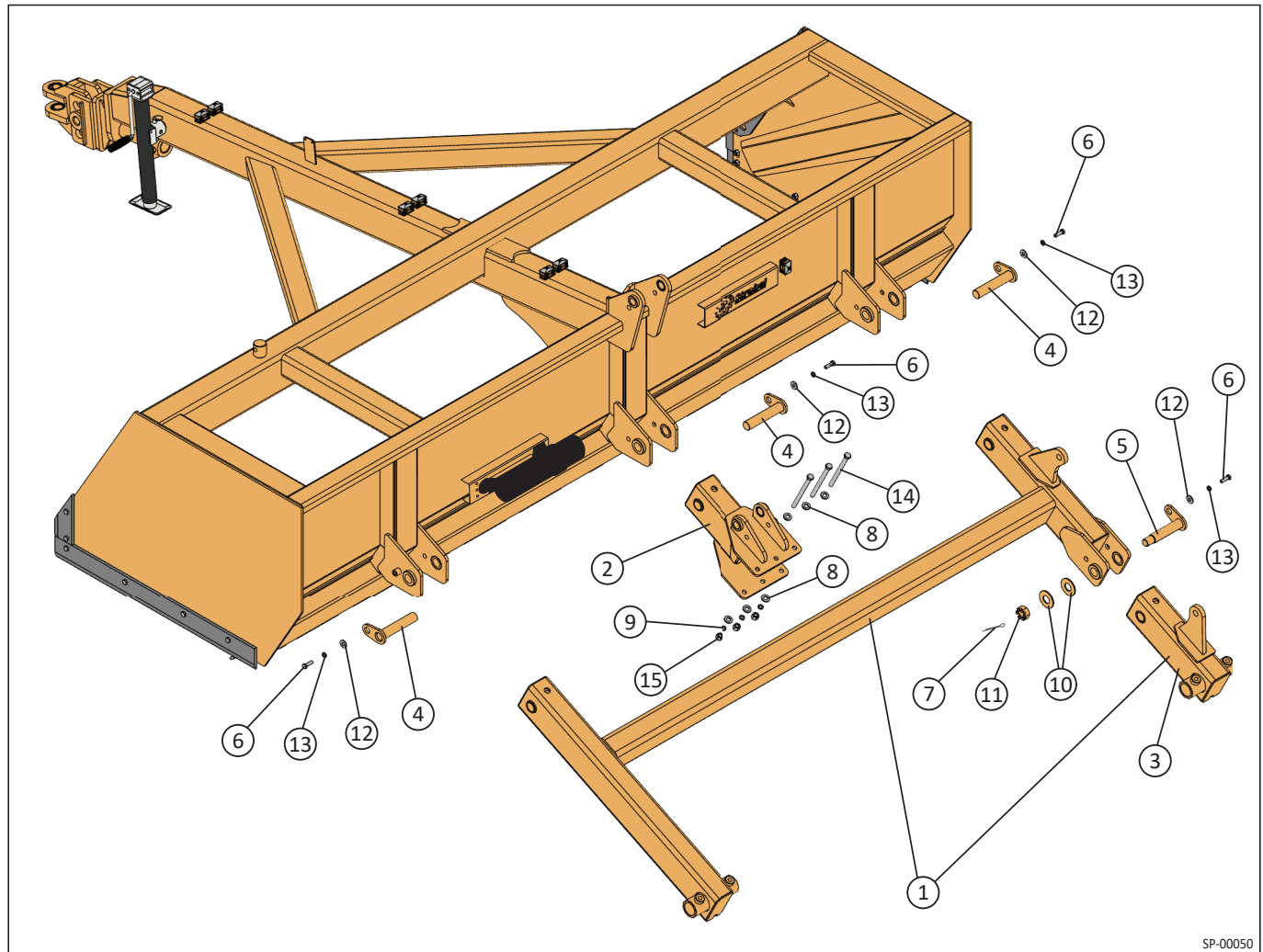

SP-00050

### Hydraulic System Replacement Parts

ID	Part Number	Qty	Description
1	03080025	4	-8 Quick Conn Coupler, 3/4 O-Ring Male
2	08180004O	2	-8 (3/4"-16) Hydraulic Handle Extend
3	08180004I	2	-8 (3/4"-16) Hydraulic Handle Retract
4	Contact Factory	1	1/2" Hyd Hose, 3/4-16 O-Ring Male, 3/4-16 JIC Female
5	Contact Factory	1	1/2" Hyd Hose, 3/4-16 O-Ring Male
6	Contact Factory	1	3/8" Hyd Hose, 3/4-16 O-Ring Male
7	Contact Factory	1	3/8" Hyd Hose, 3/4-16 O-Ring Male, 3/4-16 JIC Female
8	22020009	2	#8 SAE Female Ball Valve
9	Contact Factory	1	1/2" Hyd Hose, 3/4-16 O-Ring Male, 3/4-16 JIC Female

ID	Part Number	Qty	Description
10	Contact Factory	1	3/8" Hyd Hose, 3/4-16 O-Ring Male, 3/4-16 JIC Female
11	23160038	1	Top Lift Cylinder Pin Weldment
12	03000053	1	4" x 12" Lift Cylinder
	11190074	1	Lift Cylinder Seal Kit
13	06080004	2	90° Elbow, 3/4"-16 Male JIC, 3/4"-16 Male O-Ring
14	23160037	1	Bottom Lift Cylinder Pin Weldment
15	03000034	1	3" x 8" Tilt Cylinder
16	05000004	2	90° Elbow, 3/4-16 JIC Male, 3/4-16 NPTF Male

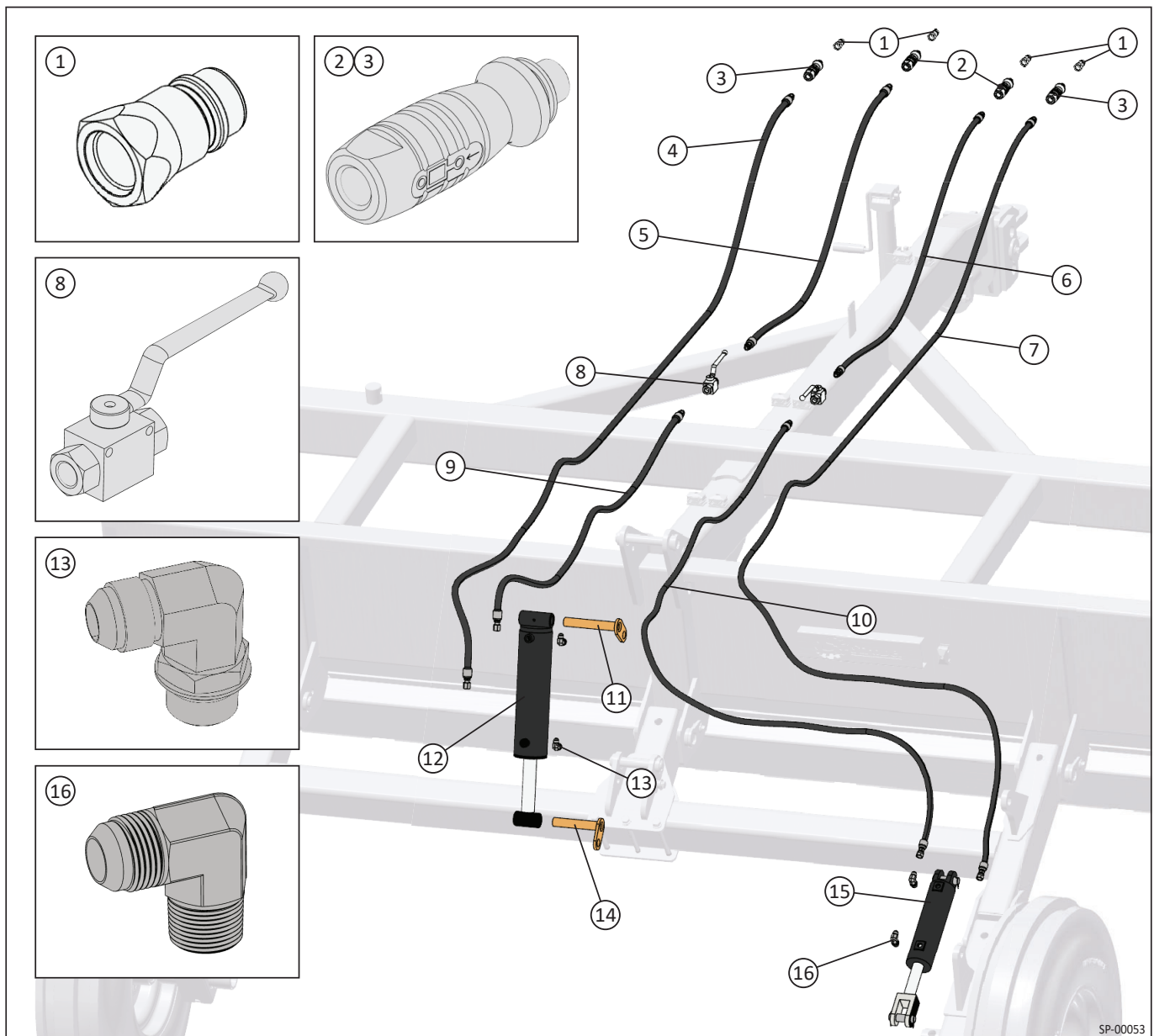

SP-00053

## Swivel Hitch Assembly

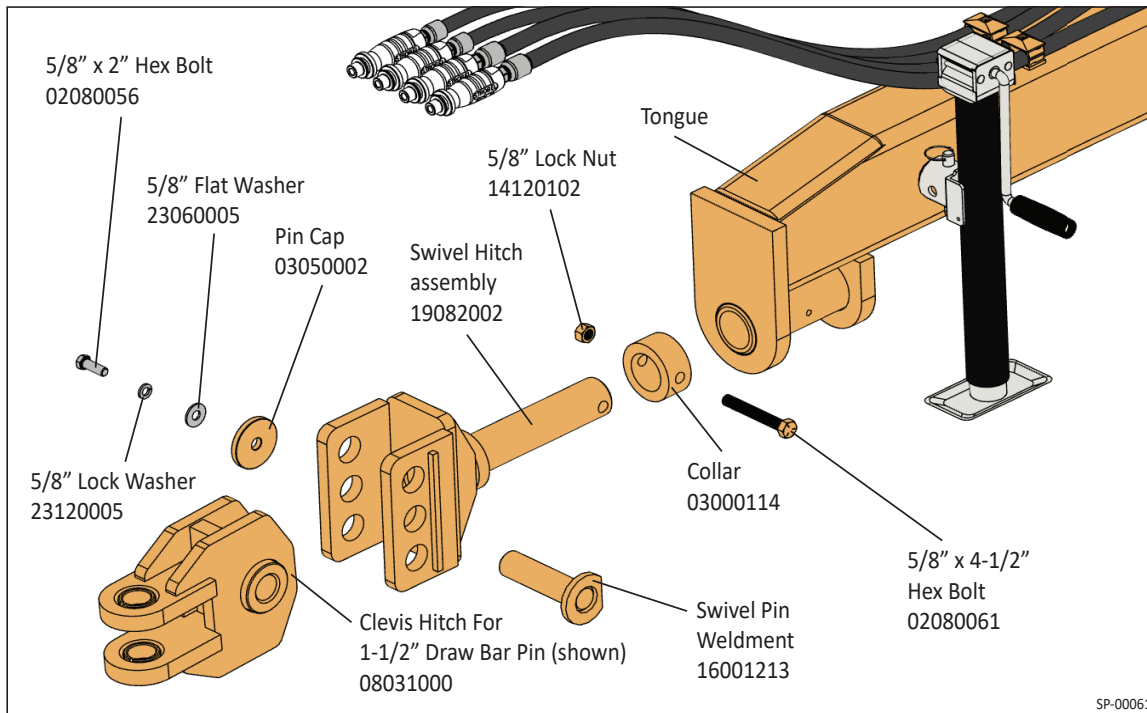

# Troubleshooting



<b>Trouble</b>	<b>Problem</b>	<b>Cause / Solution</b>
The cylinder creeps and/or will not stay in a preset position.	Seals are leaking internally.	Remove and replace the seal kit.
The scraper doesn't cut evenly.	The cutting blade needs adjustment.	Install proper shims as required to adjust the cutting blade.
	Improperly inflated tires.	Check tire air pressure. Aim to maintain the tire sidewall recommended PSI.
The implement hydraulics are not working properly.	The hoses are not plugged into the tractor properly.	Refer to the tractor manual.
Grease zerks will not take grease.	The grease zerk is plugged.	Remove and replace the grease zerk.
	The grease zerk pin is frozen.	Remove and replace the pin.



**SINCE** 1946



Since 1946 Strobel Manufacturing has been designing and building innovative, durable products that solve real-world problems. Every piece of equipment is built for rugged daily use – robust and durable. We call it Strobel Strong. Welcome to the Strobel family.

© Strobel Manufacturing, Inc. 2025 | All rights reserved.



strobelfmfg.com |     
sales@strobelfmfg.com

105 S. Green Street  
Clarks, NE 68628  
308.548.2254